

  
RADIO COMMUNICATIONS



# MT-4E Paging Systems

USER GUIDE

[www.codanradio.com](http://www.codanradio.com)



# Codan MT-4E Paging Systems

User Guide

NOTE

© 2013 Codan Limited.  
 No part of this guide may be reproduced, transcribed, translated into any language or transmitted in any form whatsoever without the prior written consent of Codan Limited.

CODAN™, NGT™, Easitalk™, CIB™ and CALM™ are trademarks of Codan Limited. Other brand, product, and company names mentioned in this document are trademarks or registered trademarks of their respective holders.

FLEX™ is a trademark of Motorola, Inc.  
 Intelligent Reference/TM-4™ is a trademark of Spectrum Instruments, Inc.  
 Acutime™ is a trademark of Trimble Navigation Ltd.  
 Thunderbolt® is a registered trademark of Trimble Navigation Ltd.  
 PURC® is a registered trademark of Motorola, Inc.  
 EDACS® is a registered trademark of Harris Corporation

The English version takes precedence over any translated versions.

DOCUMENT REVISION DEFINITION

Documentation uses a three-level revision system. Each element of the revision number signifies the scope of change as described in the diagram below.

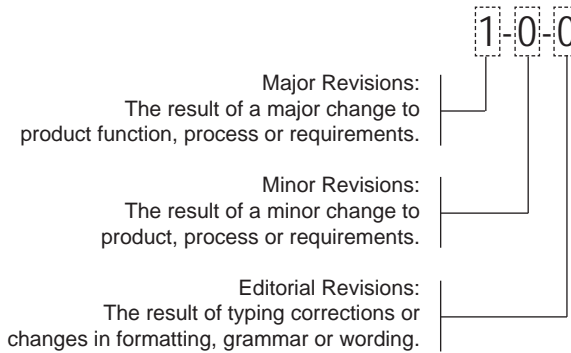

Three-level revision numbers start at 1-0-0 for the first release. The appropriate element of the revision number is incremented by 1 for each subsequent revision, causing any digits to the right to be reset to 0.

For example:

- If the current revision = 2-1-1 Then the next major revision = 3-0-0
- If the current revision = 4-3-1 Then the next minor revision = 4-4-0
- If the current revision = 3-2-2 Then the next editorial revision = 3-2-3

Document revision history is provided at the back of the document.

**Codan Radio Communications**

43 Erie Street, Victoria, BC  
 Canada V8V 1P8  
 www.codanradio.com  
 LMRsales@codanradio.com

Toll Free Canada and USA:  
 Phone: 1-800-664-4066  
 Fax: 1-877-750-0004

International:  
 Phone: 250-382-8268  
 Fax: 250-382-6139

PRINTED IN CANADA

Document Number: UG-004  
 Revision: 2-0-0  
 Revision Date: September 2013

On August 7th, 2012 - Codan Limited (ASX: "CDA") announced the acquisition of Daniels Electronics Limited, a leading designer, manufacturer and supplier of land mobile radio communications (LMR) solutions in North America. The acquisition of Daniels delivers on Codan's stated strategy of growing market share and diversifying its radio communications product offering. Codan Limited designs, manufactures and markets a diversified range of high value added electronic products, with three key business divisions; radio communications, metal detection and mining technology.

DANIELS ELECTRONICS  
IS NOW CODAN RADIO  
COMMUNICATIONS

Codan Radio Communications is a leading international designer and manufacturer of premium communications equipment for High Frequency (HF) and Land Mobile Radio (LMR) applications. We've built our reputation for reliability and customer satisfaction over 50 years in radio communications, in some of the toughest conditions on the planet.

ABOUT CODAN RADIO  
COMMUNICATIONS

For over 50 years Codan has provided customers in North America and internationally with highly reliable Base Stations and Repeaters that are environmentally robust to operate in rugged and extreme temperature conditions where low current consumption (solar powered) is a key requirement.

Codan is a pioneering member of the P25 Digital standard, for radio system interoperability between emergency response governmental organizations, providing enhanced functionality and encryption. Our products operate between 29 - 960 MHz and are available in a variety of Base Station and Repeater configurations for two way voice and mobile data applications.

Our self-servicing customers range from Forestry and National Park services through Police and Fire departments and on to Utility and Transportation groups. Our products have been deployed in every imaginable situation from the Antarctic to Hawaiian mountaintops to Alaska, enabling respondents to Forest Fires, Ground Zero rescue and routine patrols.

Codan is an industry leader in Analog and P25 radio systems design. We offer modular rack-mounted Base Stations and Repeaters capable of operating in Low Band VHF, VHF AM, VHF FM, UHF FM, 700 MHz, 800 MHz, 900 MHz

## RESOURCES

Codan Radio Communications provides many resources for the testing, tuning, maintenance and design of your Codan MT-4E Paging System.

---

#### Instruction Manuals

Codan instruction manuals are very comprehensive and include information on:

- Theory of operation
- Detailed Specifications
- Testing and tuning instructions
- Component layout illustrations

Instruction manuals can be obtained from the factory.

---

#### Technical Notes

Technical notes outline key aspects of tuning, installing, maintaining and servicing Codan Radio Systems.

Technical Notes can be found online at [www.codanradio.com](http://www.codanradio.com).

---

#### Application Notes

Application Notes provide an overview of the range of applications in which Codan Radio systems can be used.

Application Notes can be found online at [www.codanradio.com](http://www.codanradio.com).

---

#### MT-4E Analog and P25 Digital Radio Systems Maintenance Guide

The MT-4E Maintenance Guide is an aid to configuring and testing Codan MT-4E radios using an IFR 2975 Service Monitor by Aeroflex. The Guide is intended to be used with IFR 2975 Setup files that can be loaded into the Service Monitor.

The MT-4E Maintenance Guide can be found online at [www.codanradio.com](http://www.codanradio.com).

---

#### MT-4E Analog and P25 Digital Radio Systems User Guide

The MT-4E User Guide provides an overview of the configuration, operation and programming of Codan MT-4E radios.

The MT-4E User Guide can be found online at [www.codanradio.com](http://www.codanradio.com).

---

# Contents

<b>Chapter 1: Introduction to Paging</b> .....	<b>1</b>
Paging Basics .....	1
Paging Protocols.....	2
POCSAG (Post Office Code Standardization Advisory Group) .....	2
FLEX™ .....	2
Multitone Mark IV / V / VI / VII .....	2
GSC (Golay Sequential Code) .....	2
SA-206.....	2
Analog Tones .....	3
Other Paging Protocols .....	3
Other Protocols .....	4
PURC® (Paging Universal Remote Control) .....	4
TNPP (Telocator Network Paging Protocol).....	5
TAP (Telocator Alphanumeric Protocol) .....	5
Simulcast .....	6
Why use Simulcast? .....	6
Minimizing Distortion in Overlap areas .....	7
RF Frequency Stability .....	7
Audio Phase Delay and Amplitude Equalizing.....	7
<b>Chapter 2: MT-4E Paging Applications</b> .....	<b>9</b>
Base Station Paging .....	10
Remote Paging .....	11
Simulcast Paging .....	12
Simulcast Paging with RF Links .....	12
Simulcast Paging with TNPP Data Links.....	13

<b>Chapter 3: MT-4E Paging System Components</b> .....	15
Paging Encoders / Terminals and Accessories .....	16
Zetron Model 15 Paging Encoder.....	16
Zetron Model 32 / 64 Paging Terminal.....	16
Zetron Model 2100 / 2200 Paging Terminal.....	17
Zetron Model 33 Paging Network Controller .....	17
Zetron Model 66 Transmitter Controller .....	18
Zetron Model 600 / 620 Simulcast Paging System.....	18
Zetron Model 640 DAPT XTRA Dial Access Paging Terminal .....	19
Multitone Access 3000 Compact Desktop Paging System .....	19
GPS Satellite Receiver (Optional).....	20
MT-4E Receiver (Optional) and Transmitter Modules.....	21
Paging Modulator (CI-PM-3) .....	22
Subrack.....	23
Power Input .....	24
Channel and Bank Selection .....	25
A-PNL-AUX96-3 Auxiliary Connector .....	25
System Regulator .....	27
System Regulator Testing.....	28
Table 3-1: System Regulator Rotary Switch Functions .....	28
System Alarm Relay Board (Optional) .....	29
Table 3-2: SARB Standard Relay Outputs.....	29
Paging Reference Sensor Board (Optional) .....	30
Power Amplifiers .....	30
Table 3-3: RF Power Outputs .....	30
Tuning and Maintenance Tools .....	32
<b>Chapter 4: Software</b> .....	33
Connecting the PC to the Radio .....	33
Receiver and Transmitter Programming .....	34
Firmware Version Number .....	36
<b>Chapter 5: Technical Information</b> .....	37
Available Frequency Bands .....	37
Front Panel RJ45 Connector Jack .....	37
Channel Switching Range.....	37
Upgrading Firmware Versions.....	38
Paging Transmitter Block Diagram .....	38
Narrowband Paging Coverage.....	40
Configuring Daniels MT-4E Paging System.....	41
Setting the internal reference carrier frequency .....	41
Setting the 2-level or 4-level deviation.....	41
Configuring the external frequency reference .....	41



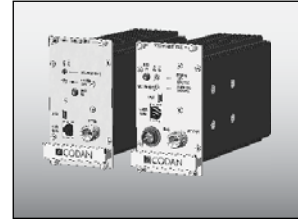

## CHAPTER 1: INTRODUCTION TO PAGING

This document is written as an introduction to Codan Radio Communications MT-4E Paging Systems. The document assumes the reader is familiar with Two-Way Radio Communications systems.

### PAGING BASICS

Paging is typically a one-way communications system. When using the paging system, users will send the paging information through a telephone system (paging terminal) or through a dispatch message center (paging encoder). Paging information is sent from the paging terminal / encoder to a paging transmitter (or transmitters), then over the air as an RF signal to everyone with a pager (paging receiver) in the system coverage area. Paging information will be in either an analog or digital format. An analog page will consist of a tone and/or voice information. A digital page requires the user to receive either numeric or alpha numeric information on an LCD display.

## PAGING PROTOCOLS

### POCSAG (Post Office Code Standardization Advisory Group)

POCSAG (also known as Radio Paging Code No. 1 or RPC1) is a one-way, 2-level FSK (Frequency Shift Key) digital encoding format that supports data rates of 512, 1200 or 2400 bps. A mix of different paging protocols or different POCSAG speeds on the same paging channel is supported. POCSAG supports tone only, numeric and alphanumeric pagers. It does not support binary data types.

### FLEX™

FLEX™ is Motorola's high-speed one-way paging protocol that supports data rates of 1600, 3200 and 6400 bps. FLEX™ supports numeric, alphanumeric and binary data types and can operate on any available paging frequency. FLEX™ can operate as a 2-level FSK at 1600 and 3200 bps and as a 4-level FSK at 3200 and 6400 bps. FLEX™ supports tone only, numeric and alphanumeric pagers. FLEX™ also supports binary data types.

### Multitone Mark IV / V / VI / VII

The Multitone Electronics Mark IV, V, VI and VII are one-way, 2-level FSK digital encoding formats, and can accommodate tone only, numeric display and voice paging. Unlike other digital formats that transmit a fixed number of binary ones and zeros in a fixed period of time, these formats require 2 milliseconds to transmit a binary 0 and 4 milliseconds to transmit a binary 1. The data transmission rate varies between 250 and 500 bits per second.

### GSC (Golay Sequential Code)

Motorola's Golay Sequential Code paging is a one-way, 2-level FSK digitally encoded format capable of transmitting tone only, numeric, alphanumeric and voice pages. The pager address information is transmitted at 300 bps while any numeric or alphanumeric data transmitted to the pager is sent at 600 bps.

### SA-206

The Load Management Format SA-206 page type is a non-paging format which is used to transmit Scientific Atlanta's proprietary protocols using Frequency Shift Keying (FSK) on existing paging infrastructure.

## Analog Tones

Analog tones can be sent as a two-tone or five / six tone format. The two-tone analog paging technique transmits two sequential audio tones, of different tone durations, to address a pager. The five / six tone analog paging format was an improvement on the two-tone format, in that it can address more pagers and can also save battery life in the pagers by addressing in groups (a group of pagers not addressed, will not come out of sleep mode, saving battery life). The analog tone encoding format can support tone only as well as tone and voice paging. In a voice page, after transmitting the tone and waiting a short period, the speaker of the pager is connected directly to the analog signal so that transmitted analog voice signals are heard on the pager.

## Other Paging Protocols

There are many other paging protocols such as the Swedish MBS format, NEC, ERMES (the European Radio Message Standard), and ReFLEX™, Motorola's two-way paging protocol.

## OTHER PROTOCOLS

### PURC® (Paging Universal Remote Control)

Paging systems can use a tone remote control sequence called PURC® (designed by Motorola) to allow a transmitter to be keyed on a specific channel and to select analog or digital mode operation. PURC® uses a standard tone remote control sequence utilizing a High Level Guard Tone (2175 Hz), Function Tone (1950 Hz), and Low Level Guard Tone (2175 Hz) as shown in Figure 1-1.

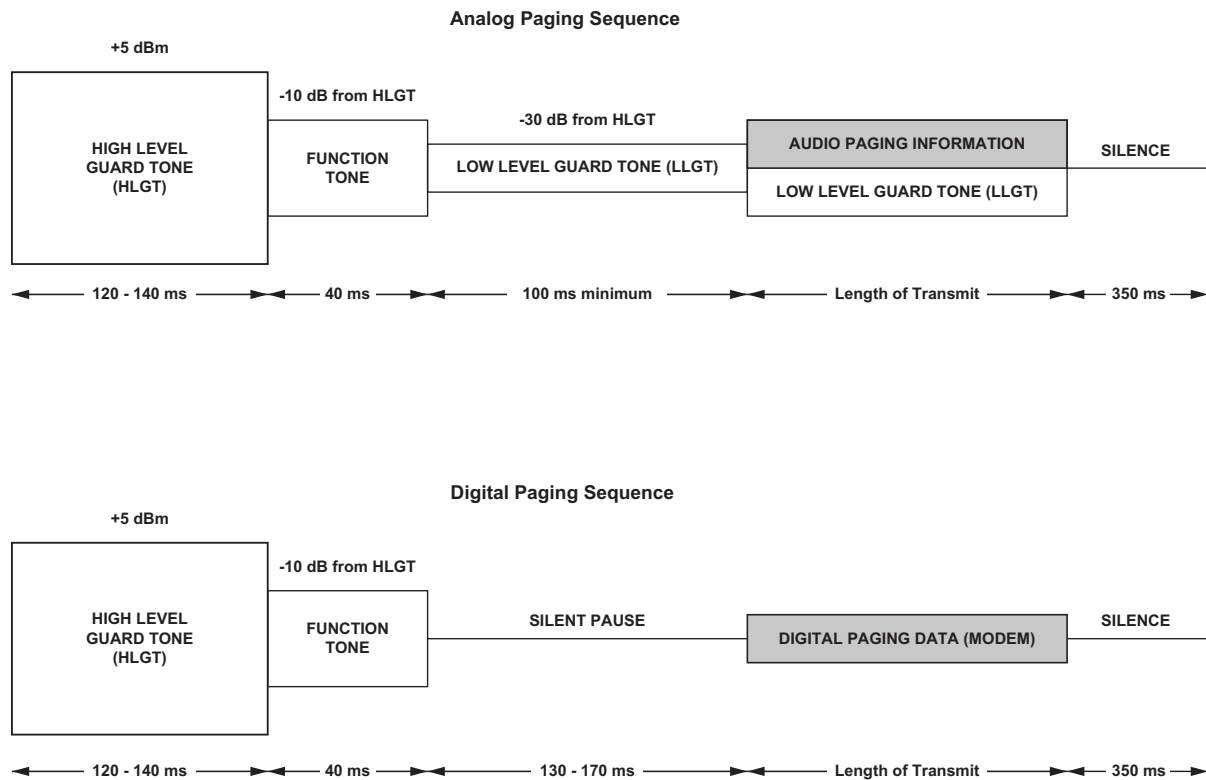

Figure 1-1: PURC® Tone Remote Sequence

The analog or digital mode of operation is determined by the presence (or absence) of the Low Level Guard Tone. The Function Tone is used to select the transmitter channel (if used). PURC® tones are within the standard audio band of 300 Hz to 3400 Hz and can be easily transmitted over an analog radio link for remote keying of paging transmitters.

## TNPP (Telocator Network Paging Protocol)

TNPP is a point to point digital communications protocol for sending pages from a paging terminal to another paging terminal, or to a transmitter controller in a paging network. TNPP is ASCII character oriented which is transmitted via a standard RS-232 asynchronous data port. The data rate can vary between 300 and 9600 baud and is determined by the application and the data network used.

## TAP (Telocator Alphanumeric Protocol)

TAP (also known as PET or IXO protocol) is as a one-way ASCII-based protocol used by a piece of equipment sending numeric or alphanumeric pages to a single paging terminal, such as an alarm monitoring system, alphanumeric message entry station, personal computer, PC network, or 3rd party email or web-based paging software. It typically operates over a serial link either directly using an RS-232 port, or over a telephone line and modem.

## SIMULCAST

Simulcast is a signaling technique that broadcasts the same signal over multiple sites in a network with precise control over frequency, phase (timing), and amplitude to avoid signal cancellation in the overlap areas. The simultaneous broadcast of a signal (analog audio, digital audio or data) by a number of transmitters on a single radio frequency from multiple transmitters can have overlapping areas. Figure 1-2 shows a simulcast system with three transmitters (Site A, B and C) on the same RF frequency.

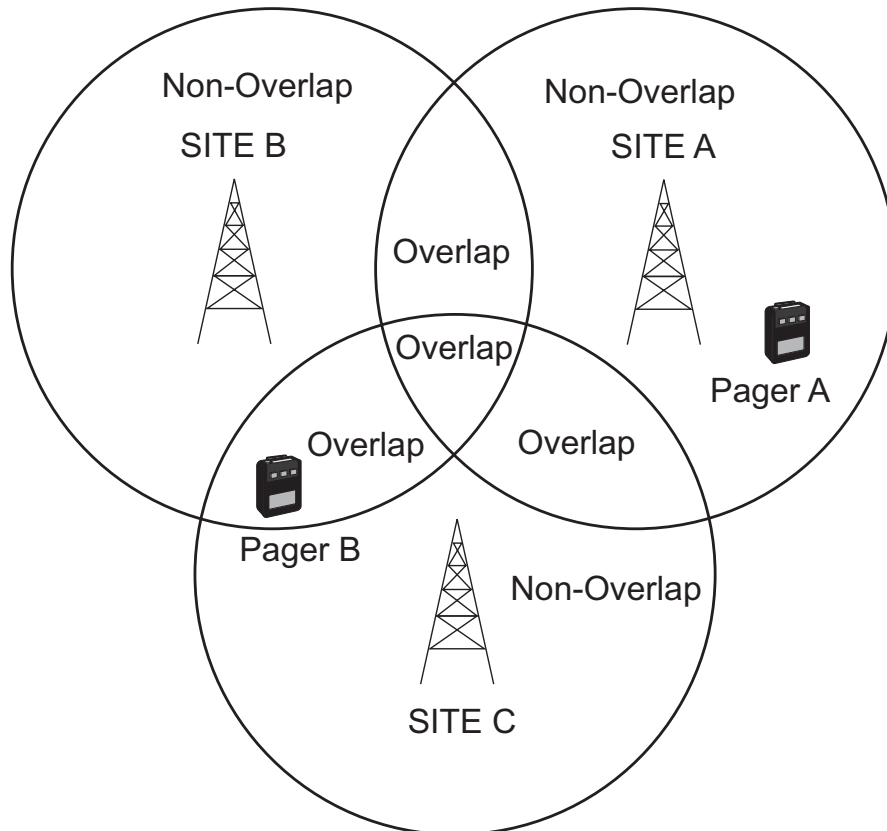

Figure 1-2: Simulcast System

In Non-Overlap areas, Pager A receives the signal from only one transmitter, which is the preferable condition. Pager B receives a signal from both Site B and Site C. This area is known as an Overlap (or non-capture) area and is the critical area in a simulcast system.

### Why use Simulcast?

Simulcast paging systems penetrate into buildings and offers seamless wide area coverage better than other methods of transmission which only use one site at a time.

Simulcast can require a more complex system design, additional RF engineering, and increased maintenance. In addition, simulcast requires more costly hardware than a conventional paging system and some systems also run the risk of having the signal blanked out in small areas by destructive interference such as multipath (a typical RF problem).

## Minimizing Distortion in Overlap areas

Overlap areas are areas in which two or more RF levels are within 10 to 15 dB of each other. Paging receivers cannot lock onto the strongest signal when RF levels are this close together and all RF signals will be received. The Overlap areas are the critical areas where the interference between the RF signals needs to be controlled. When uncontrolled, the overlapping RF signals can combine to produce an audible beat frequency in the receiver or even unintelligible audio. Differences in the audio phase and amplitude from the RF signals cause distortion in the received signal. A high degree of RF frequency stability, audio amplitude equalization and audio phase delay will minimize the distortion in these overlap areas.

## RF Frequency Stability

Synchronizing the frequencies to ensure that the frequency at all sites is extremely close together can reduce the beat note in the received signal below the audible level. Codan transmitter modules can be connected to an external high stability reference using the CI-PM-3 Paging Modulator card. The CI-PM-3 Paging Modulator uses an on-board 10 MHz OCXO frequency reference source with a standard stability of 0.35 ppm. For simulcast applications requiring a higher stability, the Paging Modulator may be configured to use an external high stability reference source (typically a GPS receiver or rubidium oscillator) with a standard stability greater than or equal to 0.002 ppm. This external reference disciplines the on-board phase-locked loop OCXO oscillator.

## Audio Phase Delay and Amplitude Equalizing

Equalizing the audio phase delay so that audio from all sources arrives at the center of the overlap area at the same time, and equalizing the audio amplitude for variations between different transmission paths will reduce the distortion of these signals received in the overlap area. Codan Paging Systems are designed for interfacing to 3rd party simulcast delay and equalizing equipment such as the Zetron Model 66 (with simulcast delay option) and Zetron Model 600/620. Connection to the Codan transmitter module is achieved via an external connection.

This Page Intentionally Left Blank



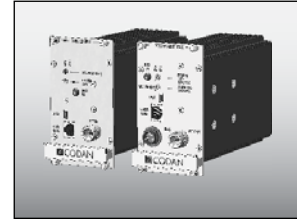

## CHAPTER 2: MT-4E PAGING APPLICATIONS

Codan Radio Communications Supports a number of different types of paging applications as shown in Figure 2-1.

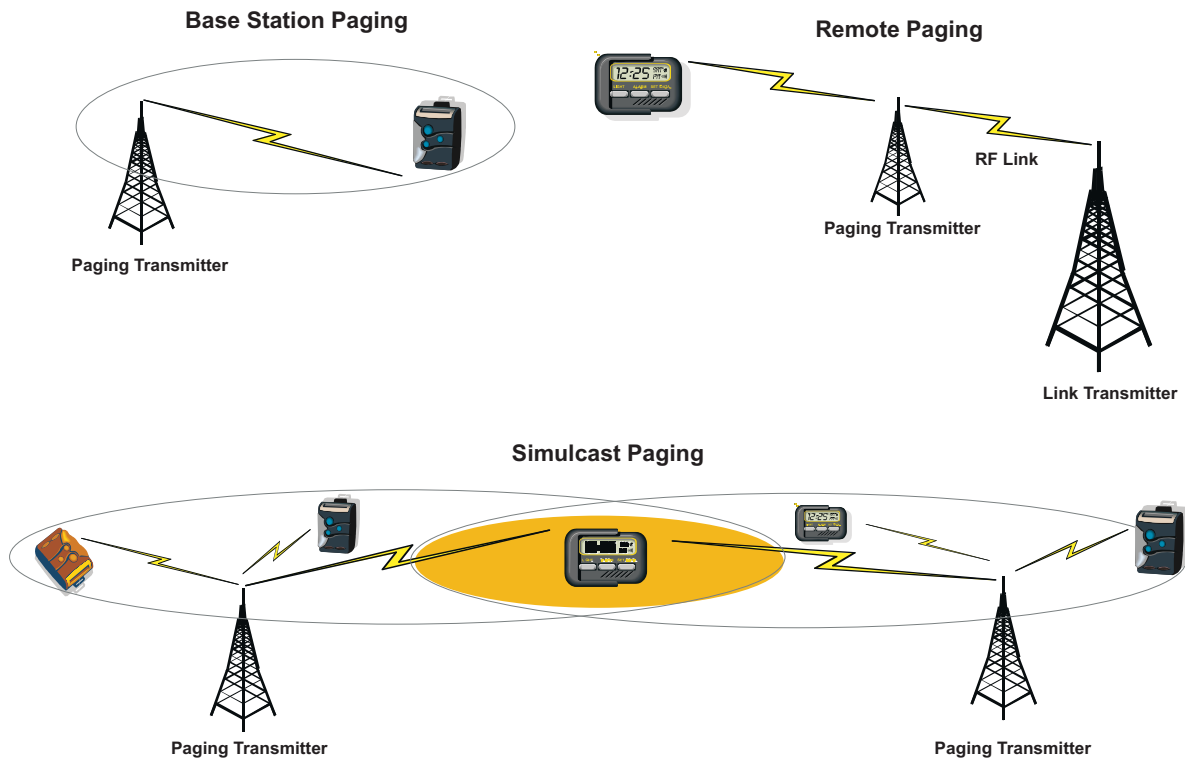

Figure 2-1: Codan Paging Applications

# BASE STATION PAGING

Base Station Paging is the one of simplest paging configurations and is shown in Figure 2-2. The paging encoder (or terminal) connects to an MT-4E transmitter, through the paging modulator, for broadcast over the local coverage area. A third party paging encoder generates the paging format for either analog (tone and voice) or digital display (numeric output). The MT-4E transmitter then sends the radio signal to the handheld pager. Optional high-power power amplifiers are available to extend the coverage area.

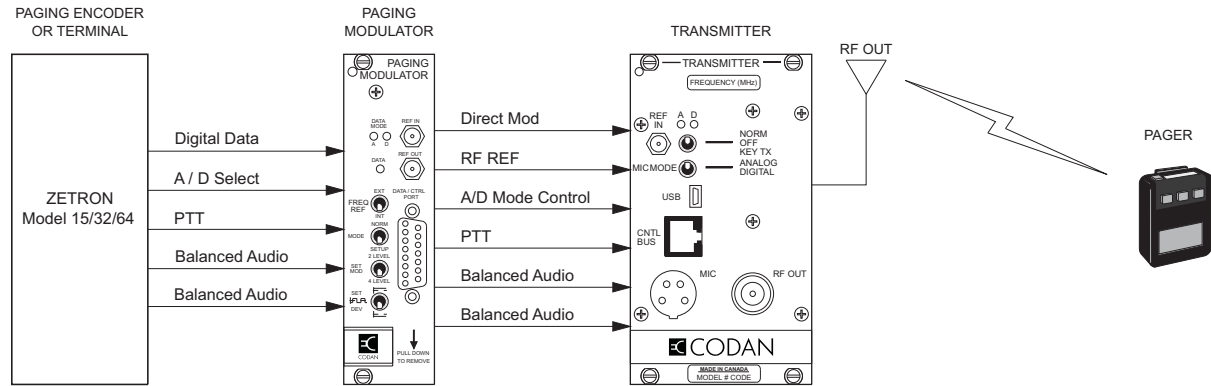

Figure 2-2: Base Station Paging

# REMOTE PAGING

Remote Paging connects the base paging transmitter to the remote paging transmitter through an MT-4E radio link for greater paging coverage. The paging encoder (or terminal) feeds the paging information to the paging network card which generates the PURC® tones which are transmitted to a remote receiver. The PURC® tones are then sent to the transmitter controller which generates the analog or digital paging format and sends them to the paging modulator and transmitter. Remote paging is shown in Figure 2-3.

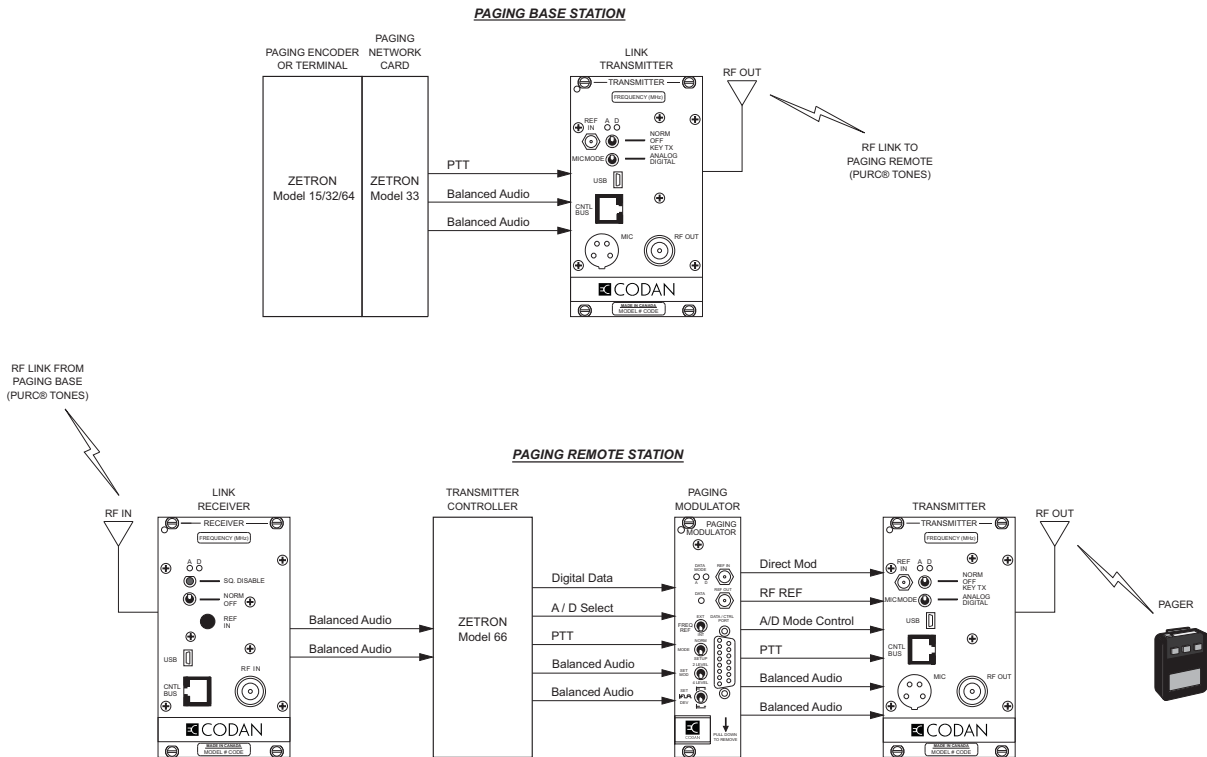

Figure 2-3: Remote Paging

# SIMULCAST PAGING

Simulcast Paging enables a message to be sent to all pagers in an overlapping coverage region simultaneously. There are two basic methods of controlling the remote paging transmitters, with RF links sending PURC® tones to transmitter controllers, or with a network sending TNPP data to wireless data encoders.

## Simulcast Paging with RF Links

Simulcast paging with RF links operates the same as remote paging except that high stability frequencies are required to frequency synchronize the multiple paging transmitters and a transmitter controller is used to equalize the audio phase delay and audio amplitude (modulation level) of the paging transmitters. Simulcast paging with RF links is capable of supporting analog or digital encoded paging information. Simulcast paging with RF links is shown in Figure 2-4

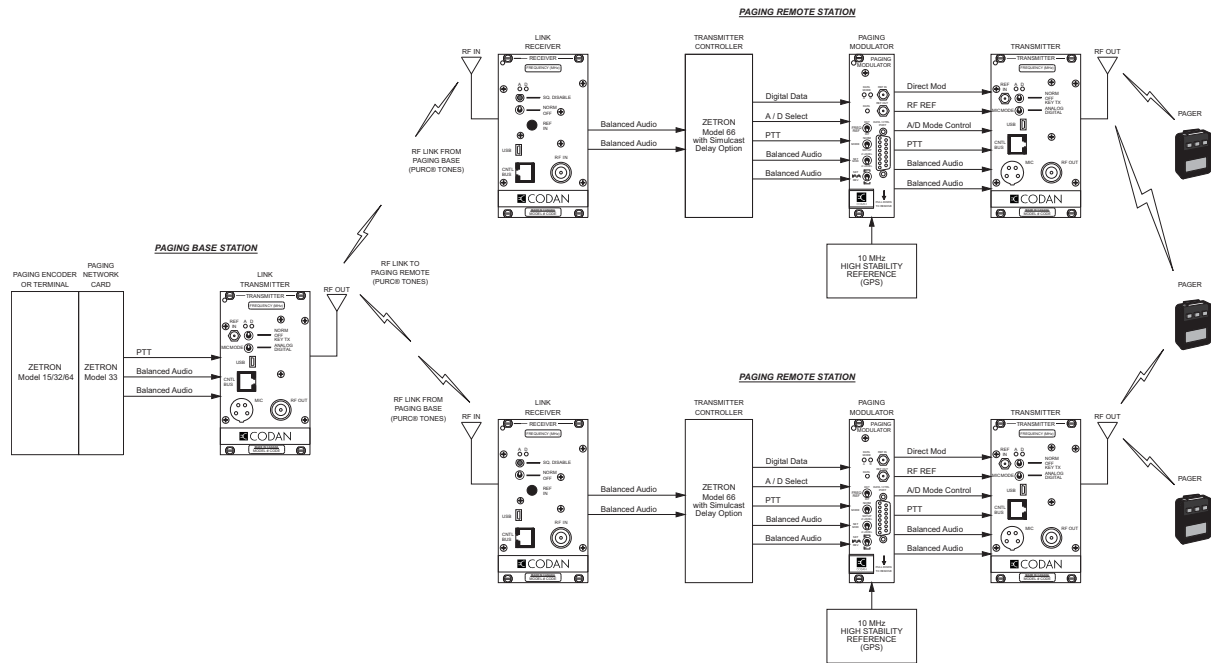

Figure 2-4: Simulcast Paging with RF Links.

## Simulcast Paging with TNPP Data Links

Simulcast paging with TNPP data links uses a wireless data manager that sends TNPP data over a network to the multiple paging transmitters through wireless data encoders. The TNPP data includes a time stamp that is referenced to GPS time, indicating when the data will be sent. Each wireless data encoder is connected to the GPS time clock for time synchronization accuracy. Simulcast paging with TNPP data links is capable of supporting digitally encoded paging information only. Simulcast paging with TNPP data links is shown in Figure 2-5.

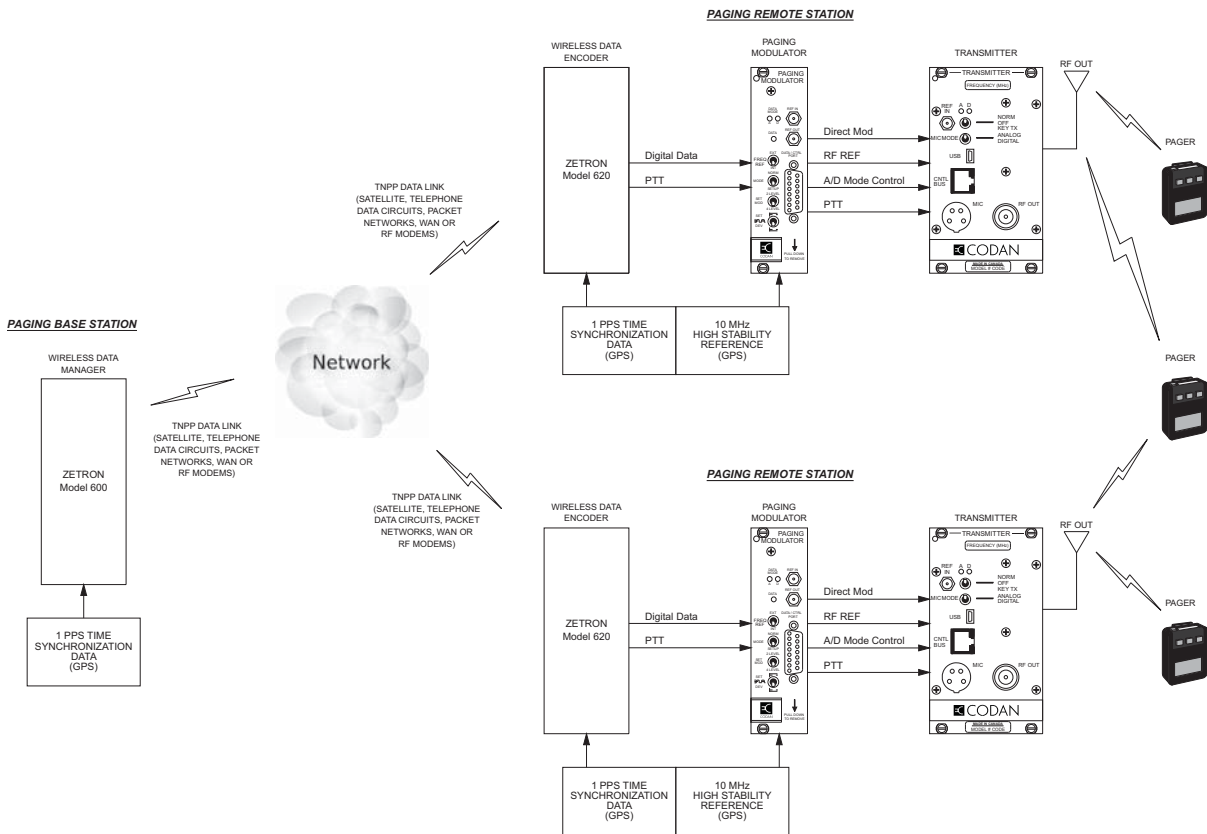
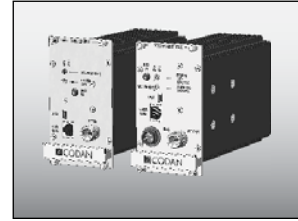

Figure 2-5: Simulcast Paging with TNPP Data Links

This Page Intentionally Left Blank



## CHAPTER 3: MT-4E PAGING SYSTEM COMPONENTS

A Codan MT-4E Paging System consists of:

- Paging Encoders / Terminals and Accessories
- GPS Satellite Receiver (optional)
- MT-4E Receiver (optional) and Transmitter Modules
- Paging Modulator (CI-PM-3)
- RSS with Programming Cable
- Subrack (with Auxiliary Connector)
- System Regulator
- System Alarm Relay Board (optional)
- Paging Reference Sensor Board (optional)
- Power Amplifiers
- Tuning and Maintenance Tools

All Codan modules are hot swappable. There is no need to disconnect the power supply when inserting or removing the modules from the subrack.

## PAGING ENCODERS / TERMINALS AND ACCESSORIES

Codan Radio Communications does not manufacture a paging encoder / terminal or accessories. There are many companies that can supply this equipment. Codan can supply and integrate these 3rd party items in an MT-4E paging system.

Zetron ([www.zetron.com](http://www.zetron.com)) has been manufacturing communications solutions for over 25 years and supplies paging solutions for many applications, from small, private paging systems to large, public paging networks.

### Zetron Model 15 Paging Encoder

The Model 15 paging encoder is designed for simple operation. The Model 15 paging encoder supports analog two-tone or five / six tone format, GSC and POCSAG (512, 1200, 2400).



Figure 3-1: Zetron Model 15 Paging Encoder

### Zetron Model 32 / 64 Paging Terminal

The Model 32 / 64 is a dial access paging terminal. The Model 32 is equipped with one incoming telephone line, and the Model 64 can be equipped with up to three incoming telephone lines. The Model 64 can provide transmitter steering for up to four transmitter zones.

Callers dial into the Model 32 / 64 and enter the number of the pager to be called. For numeric pagers, the caller enters a numeric message, which is displayed on the pager. For voice (two-tone or five-tone) pagers, the caller speaks a message which is sent to the pager. The Model 32 / 64 paging terminal has the following features:

- 
- Supports analog two-tone or five tone format
- 
- Supports digital format GSC and POCSAG (512)
- 
- Field programmable by DTMF telephone
- 



Figure 3-2: Zetron Model 32 and Zetron Model 64 Paging Terminals



## Zetron Model 2100 / 2200 Paging Terminal

The Model 2100 / 2200 paging terminals can act as the hub of an integrated communications system and are suitable for the larger private paging system. The terminals are incrementally expandable in both capacity and options, so a system can start small and grow as required. The Model 2100 / 2200 paging terminal has the following features:

- Sequential or simulcast transmitter networks supported
- Remote transmitters linked by telephone, microwave or radio links
- Supports analog two-tone or five / six tone format
- Supports digital formats GSC, POCSAG (512, 1200, 2400), Motorola FLEX™ (1600) and Multitone Mark IV / V / VI / VII
- Call logging and performance statistics
- Network multiple terminals via TNPP for wide area or regional coverage



Figure 3-3: Zetron Model 2100 / 2200 Paging Terminal

## Zetron Model 33 Paging Network Controller

The Model 33 is a remote transmitter controller which connects directly to paging encoders such as the Models 15, 32 or 64. The addition of remote control allows the paging transmitter to be located away from the paging encoder. This allows the transmitter to be located where it will provide the best coverage. The Model 33 generates the PURC® tones to be transmitted via wireline, microwave, or RF link equipment to transmitter controller equipment such as the Model 66 located at the paging transmitter sites.



Figure 3-4: Zetron Model 33 Paging Network Controller

## Zetron Model 66 Transmitter Controller

The Model 66 Transmitter Controller connects to a Codan MT-4E paging transmitter and allows the transmitter to be remotely controlled from a central paging terminal. The Model 66 recognizes the site address, selects the modulation mode (analog or digital), keys up the transmitter (by translating the PURC® tones), and transmits the audio or digital data.

Multiple transmitters can be synchronized (with optional simulcast-delay), dual-frequency transmitters can be controlled (with optional second address control), and four link “hops” are allowed (with optional link controller version). The Model 66 is GSC, POCSAG (512, 1200, 2400), FLEX™ (1600) and PURC® compatible.



Figure 3-5: Zetron Model 66 Transmitter Controller

## Zetron Model 600 / 620 Simulcast Paging System

The Model 600 / 620 Simulcast Paging System uses timing information from the Global Positioning System (GPS) to synchronize the transmission of digital paging signals to very tight tolerances. This provides the microsecond timing accuracy necessary for high-speed simulcast paging with protocols such as POCSAG (512, 1200, 2400) or FLEX™ (1600). FLEX™ (3200 or 6400) is optional.

The system consists of the Model 600 Wireless Data Manager (Source Unit) and multiple (up to 1000) Model 620 Wireless Data Encoders (Destination Units). The link between the Source and Destination units may be any type (or combination) of link that can reliably transport TNPP data.

The Model 600 accepts TNPP input from up to three TNPP links, efficiently batches the pages with timing information from an attached GPS, and delivers the pages across a network to multiple Model 620 Wireless Data Encoders. The Model 620 receives batches of paging data from the Model 600, and encodes the data for POCSAG or FLEX™. At the precise time indicated by an attached GPS, the encoded message batch is sent to the transmitter, resulting in synchronous broadcast with other Model 620 controlled transmitters.



Figure 3-6: Zetron Model 600 / 620 Simulcast Paging System

## Zetron Model 640 DAPT XTRA Dial Access Paging Terminal

The Model 640 DAPT XTRA is a combined dial access and PC driven paging terminal with up to 4 telephone lines for direct user access or for connection to local or remote data entry terminals. Voice pages and numeric or prestored alphanumeric messages may be sent from the telephone. The Model 640 paging terminal has the following features:

- Generates the PURC® tones to be transmitted via wireline, microwave, or RF link equipment
- Supports analog two-tone or five / six tone format
- Supports digital formats GSC, POCSAG (512, 1200, 2400), and Motorola FLEX™ (1600)
- Call logging and performance statistics
- Network multiple terminals via TNPP for wide area or regional coverage (optional)



Figure 3-7: Zetron Model 640 Dial Access Paging Terminal

## Multitone Access 3000 Compact Desktop Paging System

Multitone ([www.multitone.com](http://www.multitone.com)) specializes in integrated wireless communication systems and solutions to meet complex communication problems, including on-site and wide area paging systems.

The Multitone Access 3000 Compact is a self contained desktop paging system designed for single-site operation, featuring a fully integrated alphanumeric keyboard and telephone connectivity. The Access 3000 Compact paging encoder supports Multitone Mark VI and VII and POCSAG (512, 1200, 2400). The A3XC Transmitter Interface is required to connect to a Codan MT-4E paging transmitter.



Figure 3-8: Multitone Access 3000 Compact Desktop Paging System

When connecting the Multitone Access 3000 (or any other Multitone encoder) paging encoder to the CI-PM-3 paging modulator, Diode D4 on the paging modulator is required to be removed to allow the A/D select line to function properly.

## GPS SATELLITE RECEIVER (OPTIONAL)

Codan Radio Communications does not manufacture a GPS Satellite Receiver. There are many companies that can supply this equipment. Codan can supply and integrate these 3rd party items in an MT-4E paging system.

Spectrum Instruments, Inc. ([www.spectruminstruments.net](http://www.spectruminstruments.net)) specializes in high-performance, GPS disciplined precise timing, synchronization, frequency reference and signal distribution equipment. The Intelligent Reference/TM-4™ is a GPS disciplined time and frequency reference with a one pulse-per-second (1 PPS) output and high spectral-purity 10 MHz sine wave output (both outputs are BNC connectors).



Figure 3-9: Spectrum Instruments TM-4

Trimble ([www.trimble.com](http://www.trimble.com)) is a leading provider of advanced positioning solutions including GPS, laser, optical and inertial technologies. The Trimble Acutime™ Gold is a pole-mounted GPS receiver and antenna in a single environmentally sealed enclosure with a one pulse-per-second (1 PPS) RS-422 output.



Figure 3-10: Trimble Acutime™ Gold

The Trimble Thunderbolt® E GPS Disciplined Clock includes an ovenized quartz oscillator providing a stable 10 MHz and 1 PPS output (BNC connector or RS-232).



Figure 3-11: Trimble Thunderbolt® E

Trimble GPS receivers are compatible with the Zetron Model 600 / 620 Simulcast Paging System (the Trimble Acutime™ Gold can only be used for the 1 PPS time synchronization, another device would be required for the 10 MHz high stability reference).

## MT-4E RECEIVER (OPTIONAL) AND TRANSMITTER MODULES

The MT-4E receiver and transmitter modules offer high performance and low current consumption and are capable of 12.5 KHz (narrowband) and 25 KHz (wideband) paging operation. Settings such as frequency, bandwidth and power output are PC programmable via the Codan Radio Service Software (RSS).

The MT-4E receivers are used to link paging systems and are available in two versions supporting either Class A or Class B performance as defined by TIA. Class A receivers offer improved Adjacent Channel Rejection, Spurious Response Rejection and Intermodulation Rejection. Class B receivers are optimized for low power consumption.

The MT-4E receiver requires a hardware and firmware modification for Simulcast operation.

The MT-4E transmitter must be firmware version 2.2.1 and up to be used in a paging system. The MT-4E transmitters also require some minor hardware modifications to be used in a paging system. On the mainboard of the transmitter, jumper JU1 (X) needs to be removed and jumper JU1 (Y) installed to enable external selection of the Analog / Digital paging switch. Jumper JU13 (X) also needs to be removed and jumper JU13 (Y) installed to bypass the DSP and allow direct modulation of the transmitter synthesizer. The transmitter requires complete factory re-tuning at Codan after bypassing the DSP.

An optional external frequency input can also be enabled on the transmitter to allow higher frequency stability from the paging modulator.

When transmitting digital paging signals (POCSAG, FLEX™, etc), the Analog (A) LED on the transmitter will be active. The Digital (D) LED is only active for P25 Digital transmissions. The Analog / Digital MIC MODE switch on the front of the transmitter is only used for mixed mode P25 Digital / Analog systems and is not used for paging systems. The switch can be left in either position.

The MT-4E receiver and transmitter are shown in Figure 3-12.

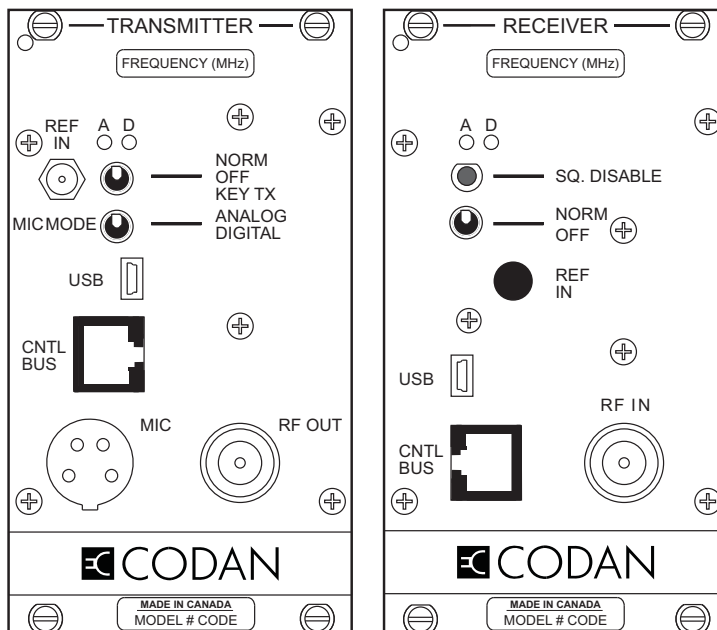

Figure 3-12: MT-4E Receiver and Transmitter

## PAGING MODULATOR (CI-PM-3)

The MT-4E modules may be configured to operate in digital and/or analog paging configurations, such as base station paging, remote paging or simulcast paging using the CI-PM-3 paging modulator. The CI-PM-3 is configured via the front panel switches and internal jumper settings.

The CI-PM-3 paging modulator is required for digital only or mixed mode (digital and analog) paging configurations, but is not required for non-simulcast, analog only paging configurations. The AC-3E audio control card can be substituted for non-simulcast, analog only paging configurations.

The CI-PM-3 paging modulator is shown in Figure 3-13.

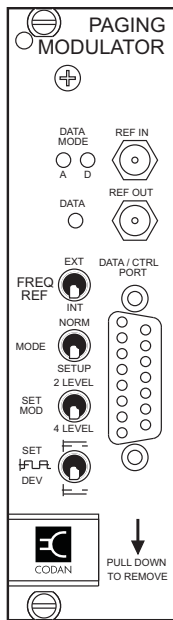

The CI-PM-3 paging modulator supports both analog and digital paging formats, and can transmit GSC, Multitone Mark IV / V / VI and VII, POCSAG and other 2-level modulation schemes at transfer rates of 512, 1200 and 2400 baud.

The CI-PM-3 supports 4-level modulation formats at data transfer rates up to 6400 bps. Each of the four modulation deviation levels can be independently set, making the CI-PM-3 suitable for use in such pager signaling schemes as Motorola's FLEX™ paging protocol.

Figure 3-13: CI-PM-3 Paging Modulator

The CI-PM-3 uses an on-board frequency reference source consisting of a 10 MHz OCXO with a frequency stability of +/- 0.35 ppm from -30 C to +60 C. For high stability applications (such as Simulcast), the CI-PM-3 paging modulator may be configured to use an external high stability reference source (i.e. rubidium, GPS or WWV) with a standard stability greater than or equal to 0.002 ppm, to discipline the on-board phase-locked loop OCXO oscillator.

The CI-PM-3 Paging Modulator includes the following standard features:

- low power analog and CMOS control circuitry (current draw of less than 250 mA).
- extended operating temperature range.
- front panel selection of PLL OCXO using external high stability frequency reference.
- jumper and line selectable analog/digital paging configuration.
- balanced 600 ohm / single-ended microphone input.
- selectable digital delay for simulcast operation.

## SUBRACK

The SR-39-1 subrack is designed to hold and interconnect the MT-4E series of receiver, transmitter and control modules on one universal motherboard. The subrack has room for two receiver and transmitter pairs. The left side connectors are reserved for transmitter A and receiver A, while the right side connectors are reserved for transmitter B and receiver B. See Figure 3-14.

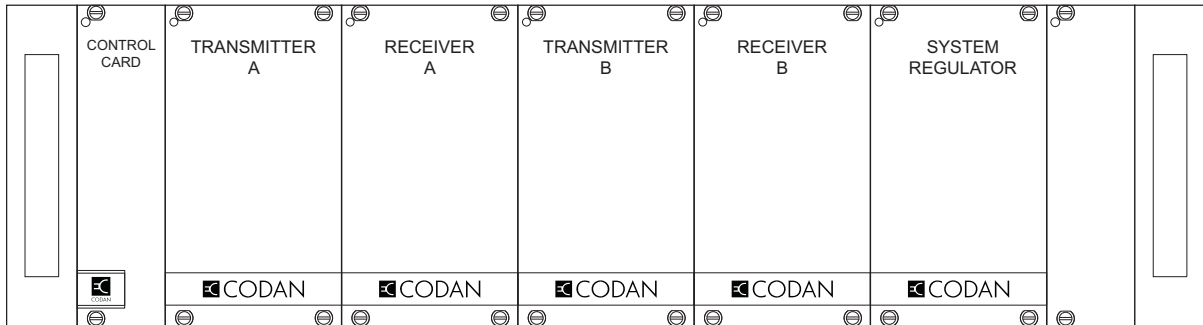

Figure 3-14: Standard Subrack Configuration

If a VHF or UHF 30 Watt power amplifier is installed, only one transmitter and receiver pair can be installed. The power amplifier takes up two slots as shown in Figure 3-15.

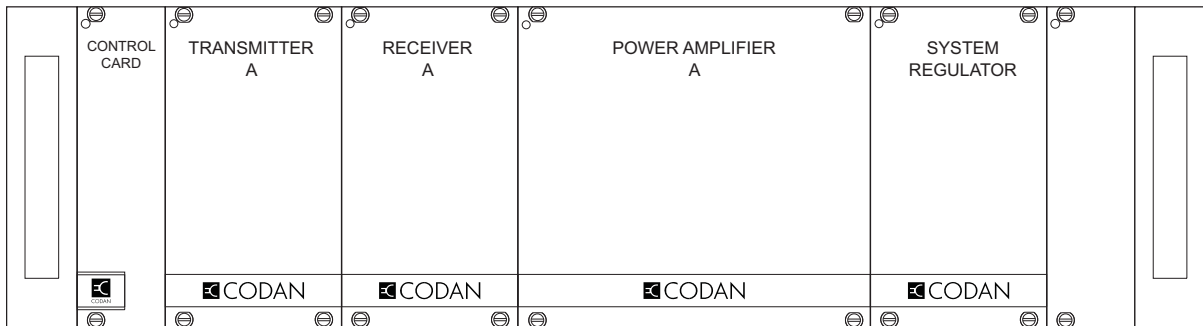

Figure 3-15: Standard Subrack with Power Amplifier

## Power Input

The main power input (+10 to +17 Vdc; +13.8 Vdc nominal) connector is located at the back of the subrack, on the motherboard. There is an identical +9.5 Vdc power output connector on the motherboard that is used to power other Codan equipment at +9.5 Vdc (the CI-RC-4M-G2 controller for example).

**NOTE:** Do not connect the main power input to the +9.5 Vdc power output connector, as a transient suppressor (over voltage protection) will short to ground to protect the equipment.

Reverse voltage protection and over voltage protection (transient suppressor) is provided at the main power input as well as the +9.5 Vdc line. The main power input is protected with a standard fast-blow 15 amp fuse. These components may require replacing if the power supply is not connected properly, or even after a power surge or a lightning strike. The two transient suppressors have different voltage ratings for the main power input and +9.5 Vdc lines. Figure 3-16 shows the subrack / motherboard rear view.

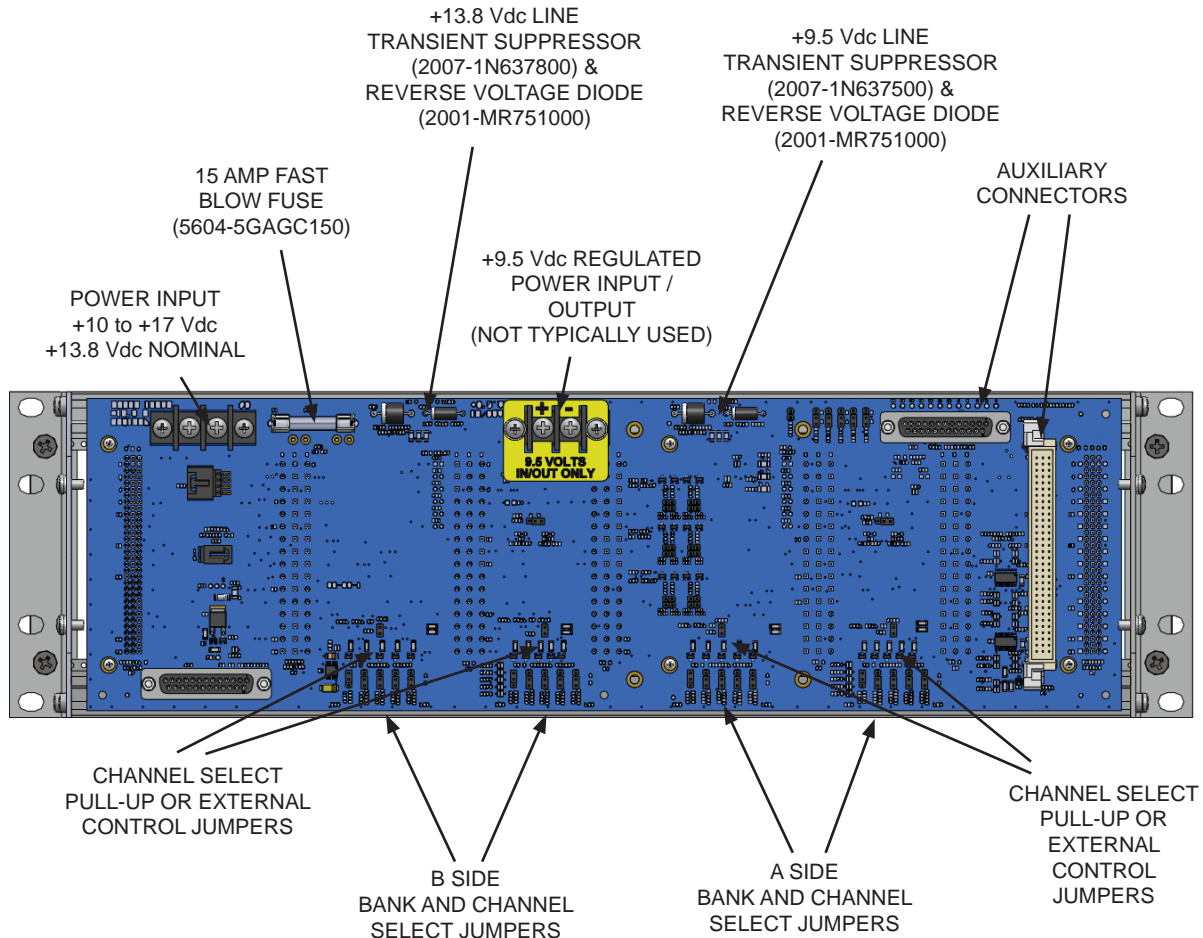

Figure 3-16: Subrack / Motherboard Rear View



## Channel and Bank Selection

Codan MT-4E receiver and transmitter modules are capable of 16 channel operation in 2 banks (32 channels total). The 16 channels are controlled via four CSEL signal lines and the two banks are controlled via a Bank A/B select line connected to each receiver and transmitter module. The CSEL and Bank A/B signal lines are set as either a 0 (0 Vdc) or a 1 (+9.5 Vdc) to select the Bank / Channel. Most paging systems operate on a single channel (Bank A, Channel 1).

## A-PNL-AUX96-3 Auxiliary Connector

An optional component that can be added to the subrack is the A-PNL-AUX96-3 Auxiliary Connector. The auxiliary connector mounts on the back wrap-around cover of the subrack and connects to the auxiliary connector on the motherboard. The A-PNL-AUX96-3 brings all of the auxiliary connector signal lines out to screw terminals for easy connection. These connections are ideal for interfacing external equipment and allowing easy access for testing and tuning points. The A-PNL-AUX96-3 Auxiliary Connector and the back wrap-around cover are shown in Figure 3-17.

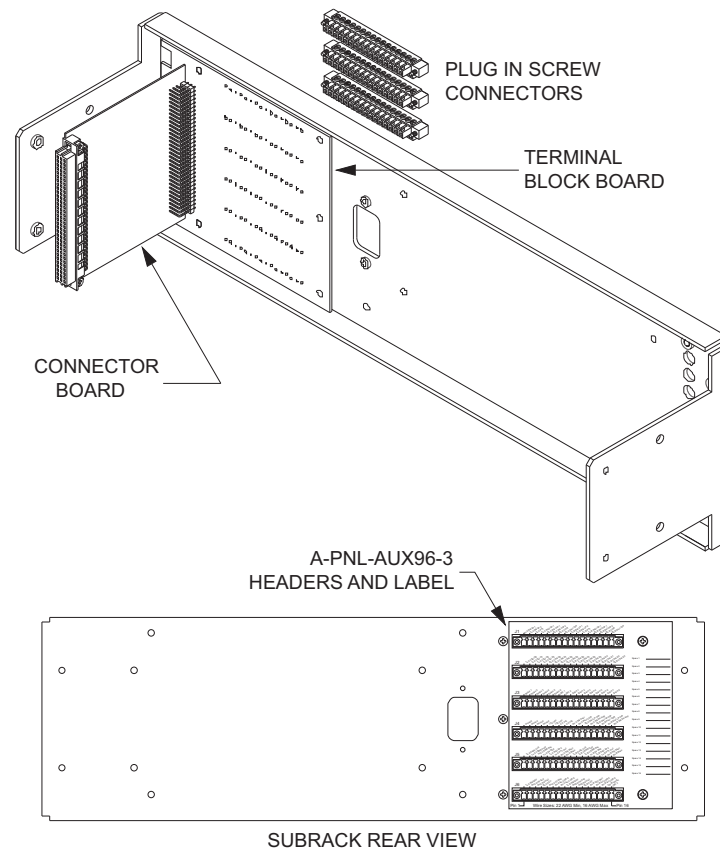

Figure 3-17: Auxiliary Panel Diagram

A close-up view of the auxiliary connector label, as shown in Figure 3-18, indicates the short signal name for each connection point. Definitions for these signals can be found in the SR-39-1 subrack manual. Extra General Purpose Input / Output connectors (GPIO) that can be used for different functions depending on the control card are listed to the right of the connectors. The custom functions of these connectors for the CI-PM-3 paging modulator are marked in the blank space next to the signal name.

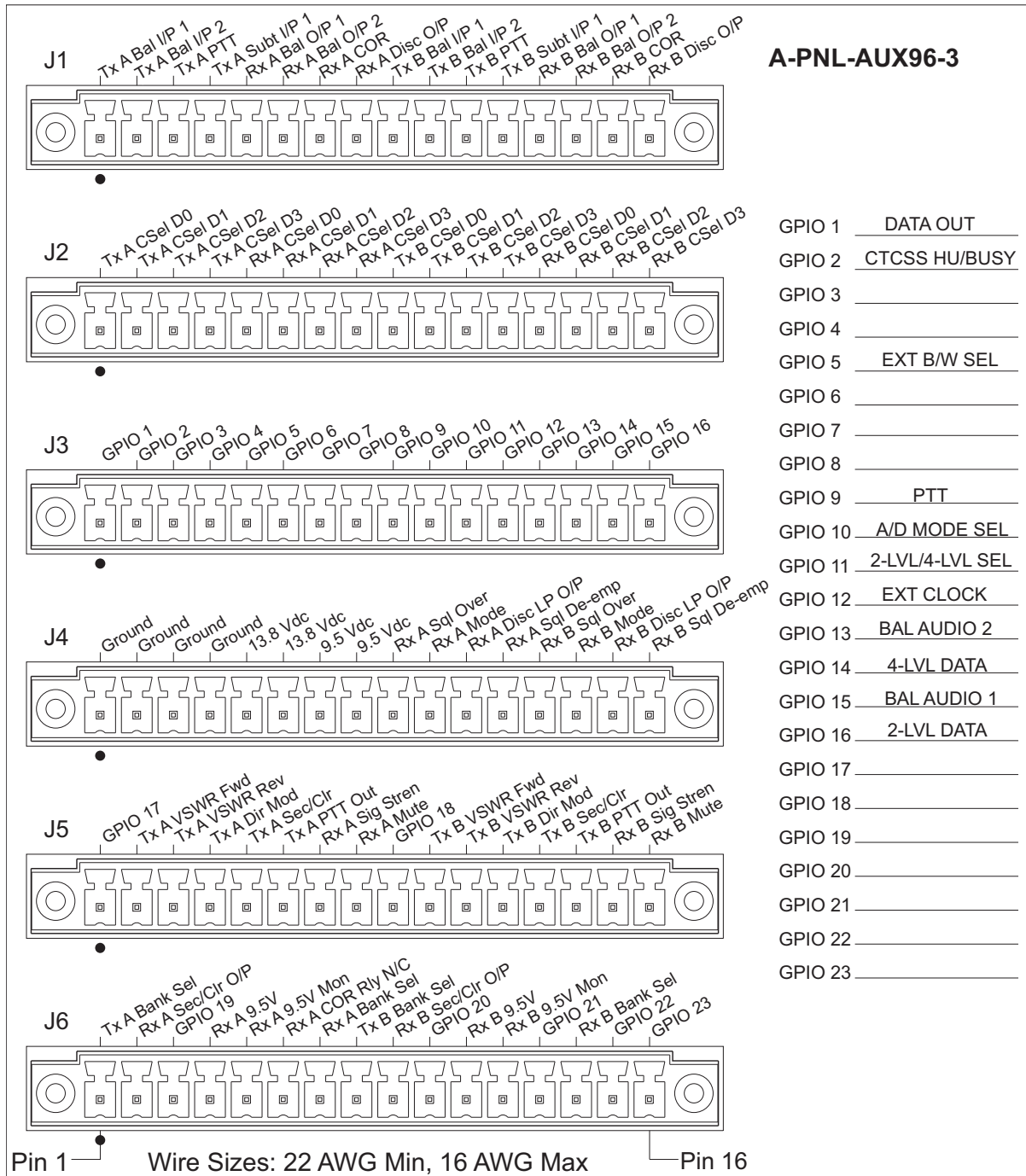

Figure 3-18: Auxiliary Panel Pin-Out

## SYSTEM REGULATOR

The SM-3 system regulator is a plug-in module which provides voltage regulation, system metering and audio monitoring for an MT-4E paging system. The SM-3 includes the following features:

- High current +9.5 Vdc voltage regulator with an anti-latchup hysteresis circuit.
- Front panel switch selectable meter outputs to check supply voltages, regulated voltages, etc.
- Audio amplifier and loudspeaker.
- Relay drivers for optional antenna relays.

There are several different models of System Regulators as shown in Figure 3-19. The basic SM-3 is the same size as a transmitter or receiver module. The System Regulator can also be purchased with 1 or 2 optional antenna relays.

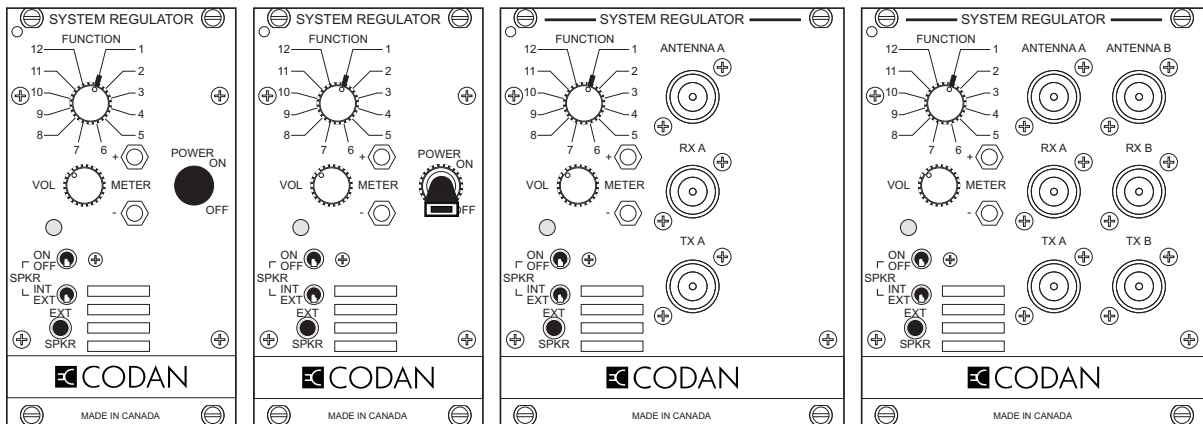

Figure 3-19: System Regulators

## System Regulator Testing

The System Regulator module is designed with a convenient and easy test point built in to the front panel. This test point allows a technician access to the DC supply and regulated voltages. Simply connect a standard Digital Volt Meter (DVM) to the METER jacks on the front panel of the System Regulator as shown in Figure 3-20. Turn the rotary switch to the desired position to measure the supply voltage, regulated voltage or audio output as shown in Table 3-1. Note that the RSSI requires a carrier and the audio output requires an audio tone injected into the receiver.

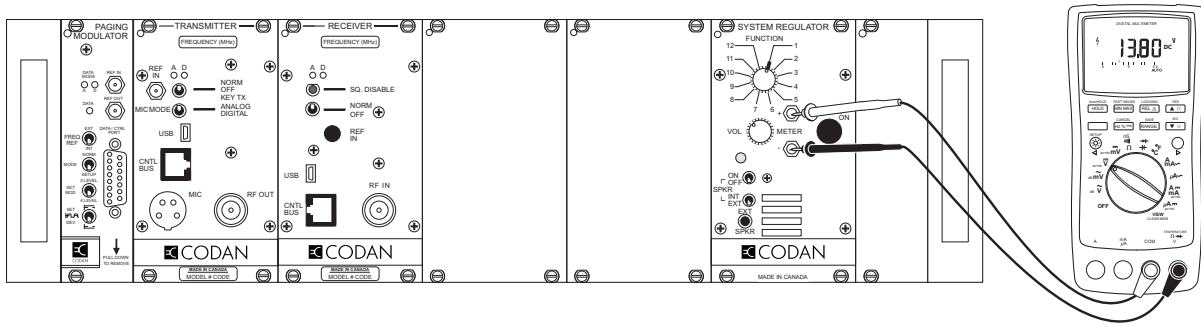

Figure 3-20: System Regulator Testing

Table 3-1: System Regulator Rotary Switch Functions

Position	Function	Parameter
1	Supply Voltage	+10 Vdc to +17 Vdc (+13.8 Vdc nominal)
2	+9.5 Volts Regulated	+9.5 Vdc ( $\pm 0.1$ Vdc)
3	Rx A Audio	Receiver A Audio (NOT Rx Balanced Output)
4	Rx A Carrier Strength	0 Vdc to +5.0 Vdc based on received signal strength (0 Vdc is a low RF signal level, +5.0 Vdc is high)
5	Rx B Audio	Receiver B Audio (NOT Rx Balanced Output)
6	Rx B Carrier Strength	0 Vdc to +5.0 Vdc based on received signal strength (0 Vdc is a low RF signal level, +5.0 Vdc is high)

## SYSTEM CONTROL AND ALARM RELAY BOARD (OPTIONAL)

The System Control and Alarm Relay Board (SCARB) is a module developed to handle alarm outputs and to add control functionality to MT-4E systems.

### Relays

The SCARB contains five standard relays and three optional relays. The standard relays are for Transmitter Forward Power Alarm, Transmitter VSWR Alarm, Paging Reference Failure Alarm, 100 Watt Power Amplifier Alarm and AC Power Supply Failure Alarm.

These relays have normally open (N/O), normally closed (N/C) and common (COMM) outputs. Table 3-2 lists the standard configuration with available alarm lines and their associated relays and connector pins.

Table 3-2: SCARB Relay Outputs

Alarm Line	Relay	Connectors	
Transmitter (A and/or B) Forward Power Alarm (transmitter power output drops below half of the set level)	RLY1	J4-11	N/O
		J4-12	COMM
		J4-13	N/C
Transmitter (A and/or B) VSWR Alarm (transmitter VSWR is higher than 3:1)	RLY2	J4-14	N/O
		J4-15	COMM
		J4-16	N/C
Paging Reference Failure Alarm (external reference fails or drifts to far)	RLY3	J5-10	N/O
		J5-11	COMM
		J5-12	N/C
100 Watt Power Amplifier Alarm (Input J5-8) (power amp output power drops to 80%; or VSWR exceeds 2.5:1; or high temperature)	RLY4	J2-13	N/O
		J2-14	COMM
		J2-15	N/C
AC Power Supply Failure Alarm (Input J5-9) (AC power failure)	RLY5	J6-1	N/O
		J6-2	COMM
		J6-3	N/C
Spare Alarm 1 (Input J6-4) (open/ground or variable voltage activation)	RLY6	J6-7	N/O
		J6-8	COMM
		J6-9	N/C
Spare Alarm 2 (Input J6-5) (open/ground or variable voltage activation)	RLY7	J6-10	N/O
		J6-11	COMM
		J6-12	N/C
Spare Alarm 3 (Input J6-6) (open/ground activation or Low System Voltage Alarm Option - 10 Vdc or 11 Vdc activation)	RLY8	J6-13	N/O
		J6-14	COMM
		J6-15	N/C

## Power Control Lines

Optional power control lines provide a variable power output setting for specific 100 Watt Power Amplifiers. The two power control, resistive lines are either activated or disabled depending on the logic state (12 Vdc active high) of the inputs at J5-5 and J5-6. When these lines are activated, they create a resistance parallel to pin SH/D on the power amplifier, varying the impedance on this pin and controlling the output power of the amplifier. The resistances on the two respective parallel lines are adjusted using RV1 and RV2, allowing for various output power settings.

## PTT and A/D Control Lines

The PTT and A/D Control Lines on the SCARB board are custom inputs designed to control the CI-PM-3. The first four inputs on the J5 Pins 1–4 can be connected to various products to remotely enable and disable PTT and A/D inputs to the paging card.

Optional Remote PTT and PTT Disable logic control lines give the paging system ability to prioritize PTTs and select the paging mode - either allowing analog paging only or allowing both analog and digital paging.

The A-PNL-SCARB-01 Connector replaces the A-PNL-AUX96-3 Auxiliary Connector. The SCARB mounts on the back wrap-around cover of the subrack and connects to the auxiliary connector on the motherboard. A close-up view of the SCARB connector label is shown in Figure 3-21.

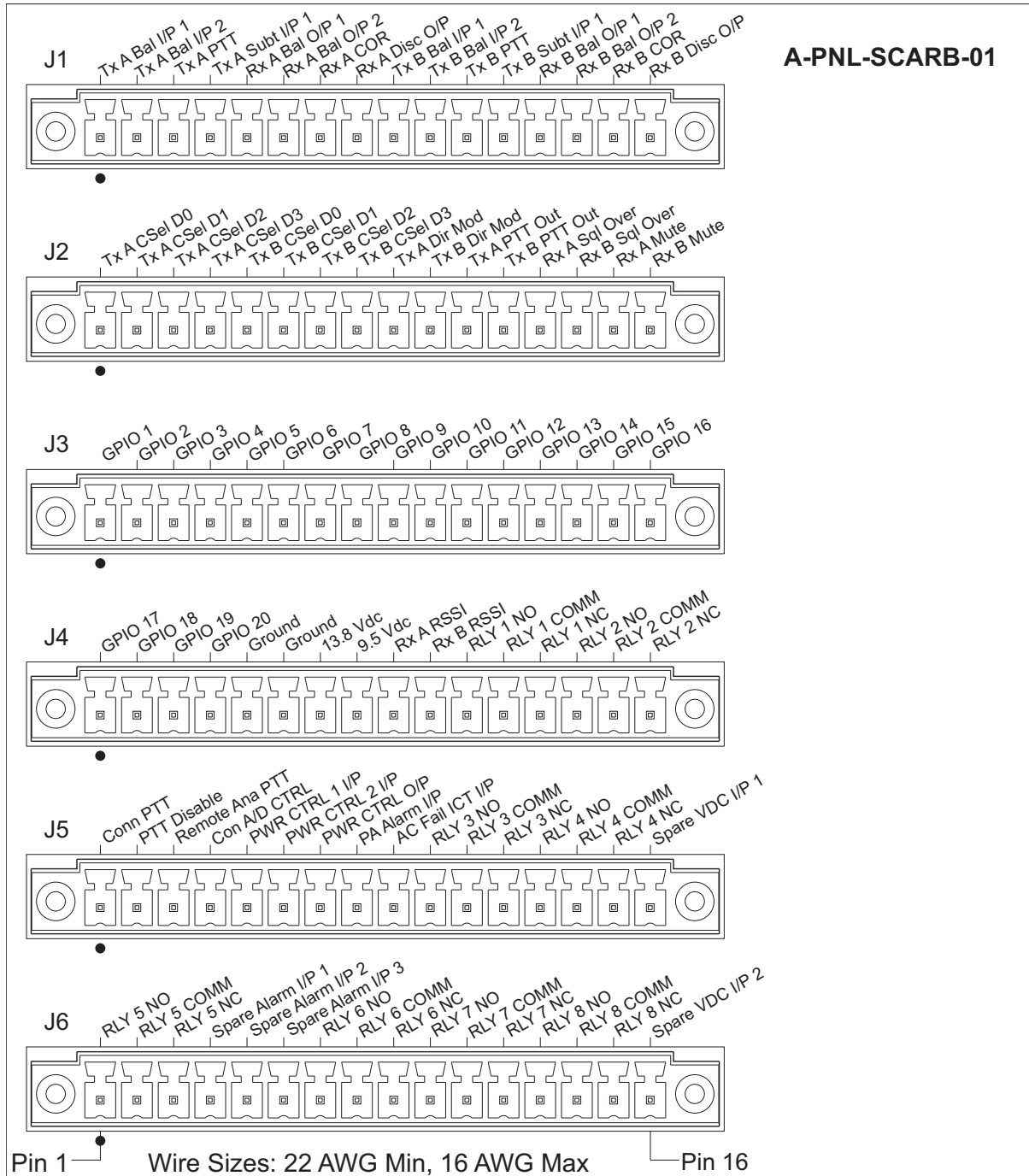

Figure 3-21: System Control and Relay Board Pin-Out

## PAGING REFERENCE SENSOR BOARD (OPTIONAL)

The Paging Reference Sensor Board is an additional option for the Paging Modulator (CI-PM-3) and System Alarm Relay Board (SCARB) for simulcast systems that require high stability of paging signals.

The board works in conjunction with the paging modulator’s on-board PLL circuit. It is designed to protect paging systems from external reference failures and indicate that a failure has occurred. The alarm output will be triggered if the external reference fails.

## POWER AMPLIFIERS

Table 3-3 shows the RF Power outputs for the transmitter modules in each frequency band.

Table 3-3: RF Power Outputs

Band	Frequency	Transmitter
VHF Highband	136 - 174 MHz	0.5 to 8.0 Watts
UHF 400 MHz	406 - 470 MHz	0.5 to 8.0 Watts
UHF T-Band	470 - 520 MHz	0.5 to 6.0 Watts
UHF 700 / 800 MHz	768 - 869 MHz	0.5 to 3.0 Watts
UHF 900 MHz	896 - 960 MHz	0.5 to 3.0 Watts

If a higher RF power output is required, the transmitter may be used as an exciter to drive a power amplifier. Codan Radio Communications manufactures a 30 Watt power amplifier for VHF highband and UHF 400 MHz, shown in Figure 3-22 that will fit into a standard subrack.

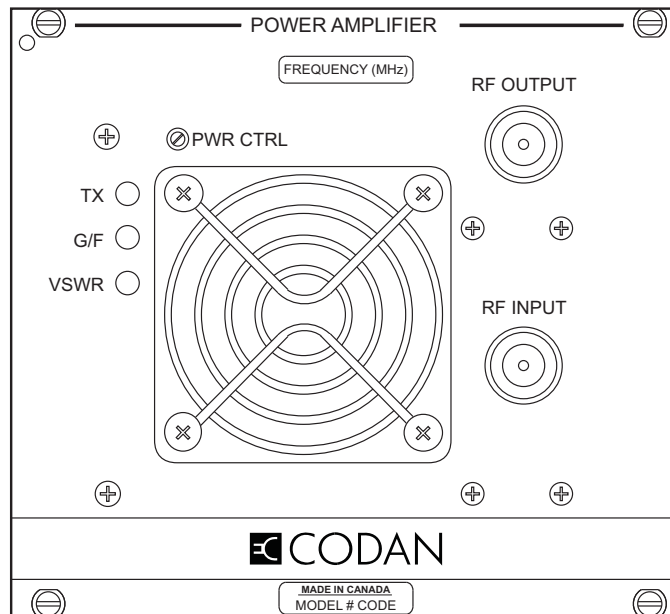

Figure 3-22: 30 Watt Power Amplifier



Codan Radio Communications can also supply higher power amplifiers that are 19" rack mountable as shown in Figure 3-23. All transmitters and power amplifiers are rated for 100% continuous duty.

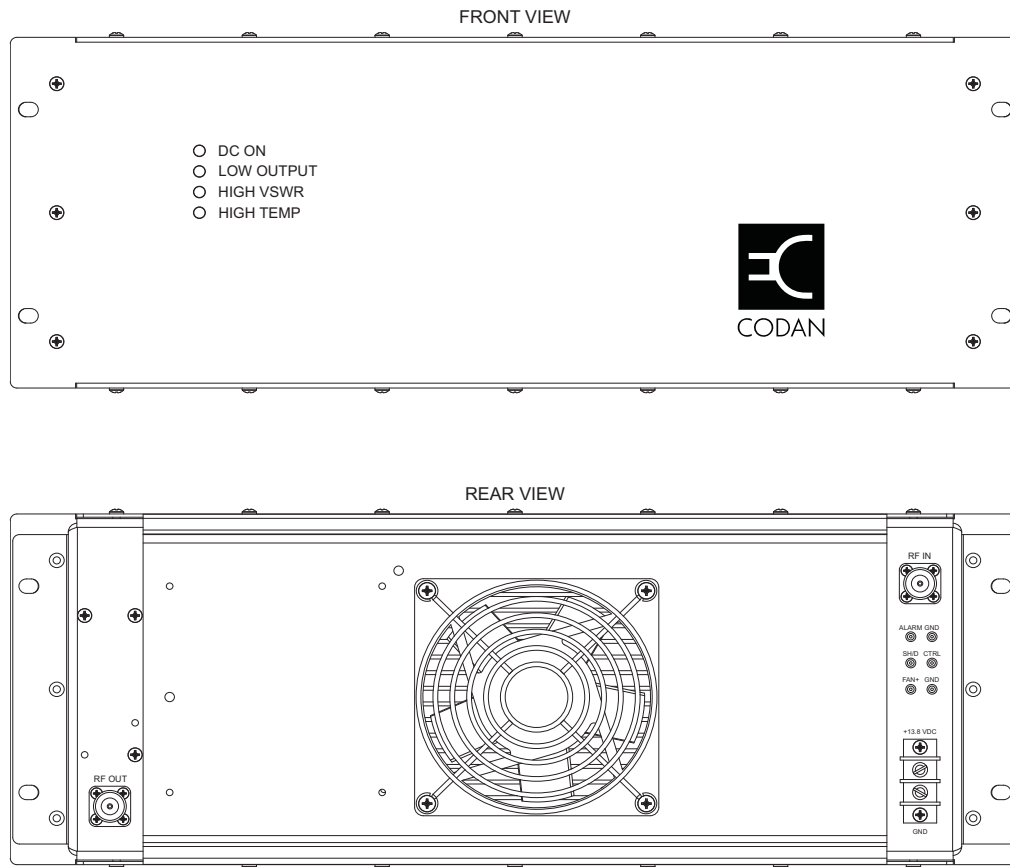

Figure 3-23: 100 Watt Power Amplifier

## TUNING AND MAINTENANCE TOOLS

To facilitate testing, alignment and maintenance for the MT-4E paging systems, extender cards can be used to extend the individual modules out from the subrack. Extender kits (extender card plus a four-foot cable) allow the modules to be extended out to a bench for servicing.

The following extender cards and kits are available:

---

**EC-96D1** (direct connect) or **EC-96K-1.22** (card and cable)

Used for the 96 pin CI-PM-3 paging modulator.

---

**EC-48RD** (direct connect) or **EC-48RK-1.22** (card and cable)

Used for all receiver, transmitter, power amplifier and system regulator modules.

---

Figure 3-24 shows the 96 pin and 48 pin direct connect extender cards.

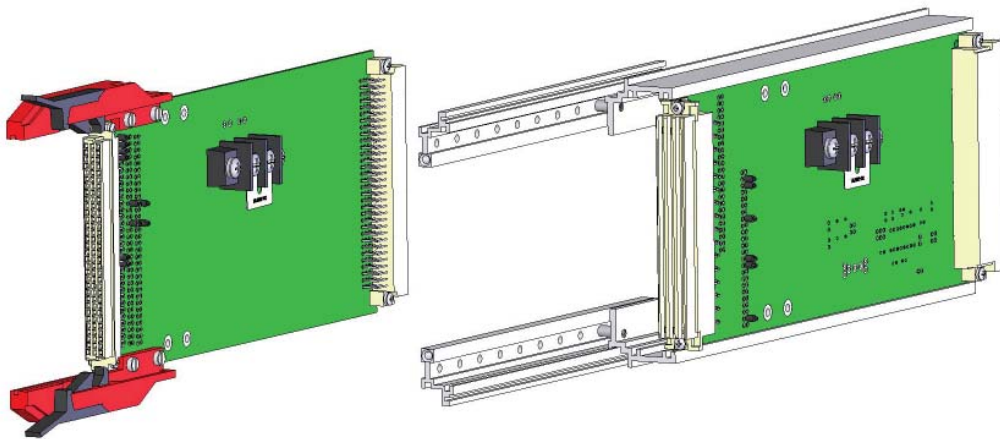
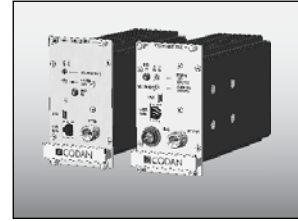

Figure 3-24: EC-96D1 and EC-48RD Direct Connect Extender Cards

The **A-TK-04** tool kit includes a number of spare parts for the MT-4E paging system, including tuning tools, guide rails, transient suppressors, diodes, a fuse, dust caps, shunt jumpers, ESD wrist strap, and various screws and hardware.



## CHAPTER 4: SOFTWARE

### CONNECTING THE PC TO THE RADIO

The RSS programming software will run on a PC with Windows 98, 2000, XP, Vista and 7 (32 or 64 bit) operating systems. A type A to 5 pin mini-type B USB cable is used to connect the USB port of the computer to the USB port on the front panel of the Receiver or Transmitter module as shown in Figure 4-1.

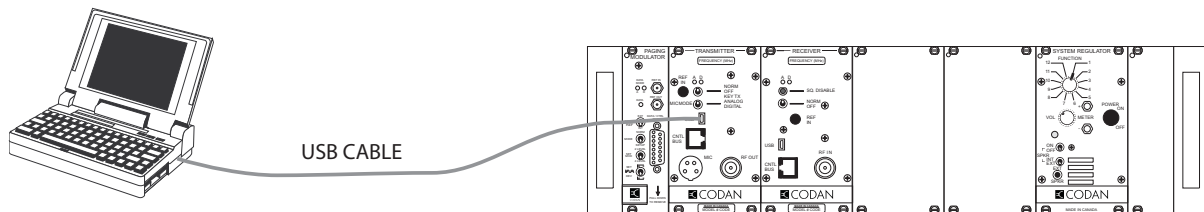

Figure 4-1: PC to Radio RSS software connection

## RECEIVER AND TRANSMITTER PROGRAMMING

The RSS programs the Receiver and Transmitter modules independently. The programming software must be version 1.2.4.6 and up to be used for a paging system. The programming cable must be connected to the module being programmed.

The MT-4E Transmitter programming screen is shown in Figure 4-2.

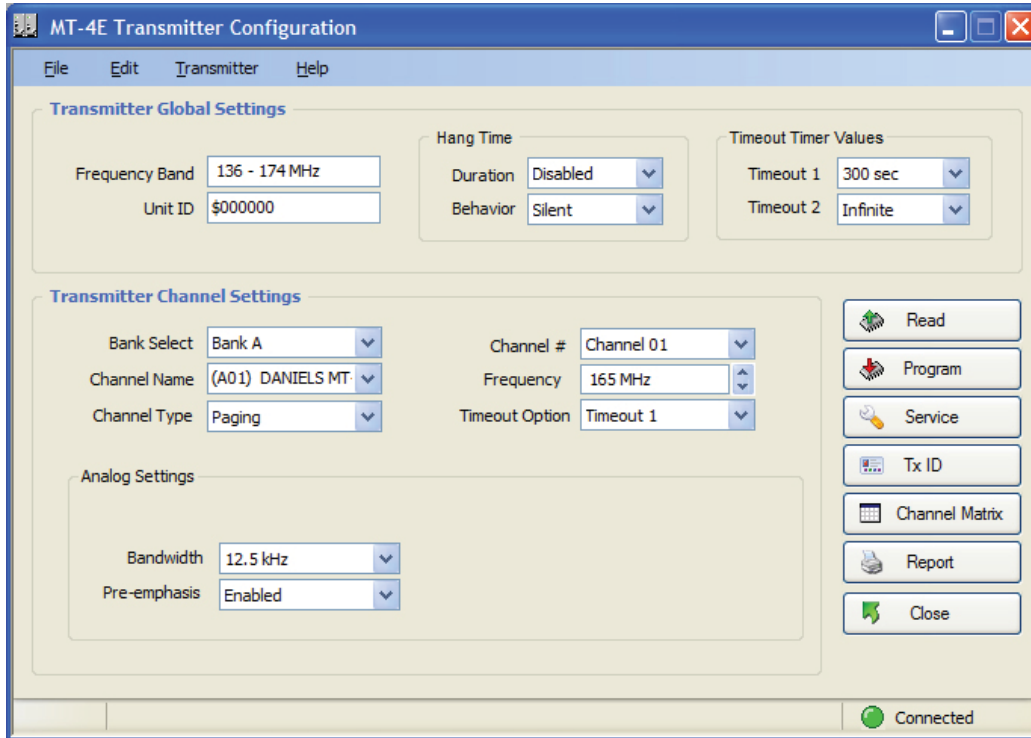

Figure 4-2: MT-4E Transmitter Program Example

The Synthesizer Reference should be set to External using the Transmitter Jumper Settings in the Service section.

The Transmitter Jumper Settings screen is shown in Figure 4-3.

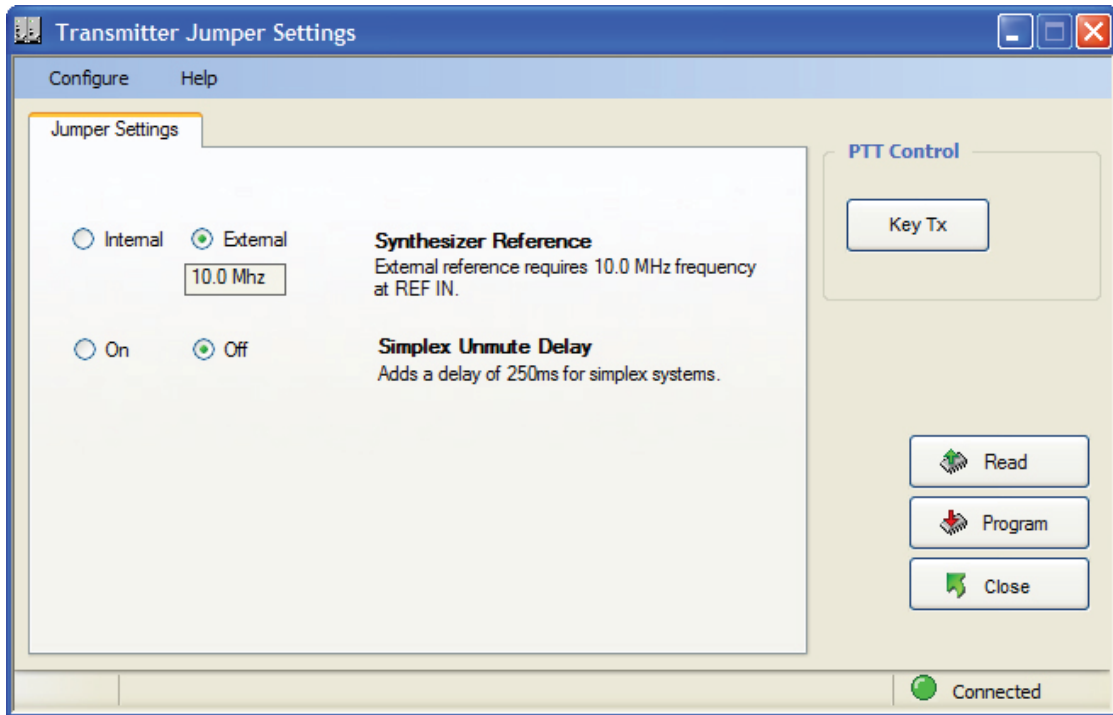

Figure 4-3: Transmitter Jumper Settings

## FIRMWARE VERSION NUMBER

Information on the Receiver or Transmitter serial number, firmware version, model number, synthesizer information and user names can be found by clicking on Rx ID or Tx ID in the Receiver or Transmitter configuration screen.

The Transmitter ID screen is shown in Figure 4-4.

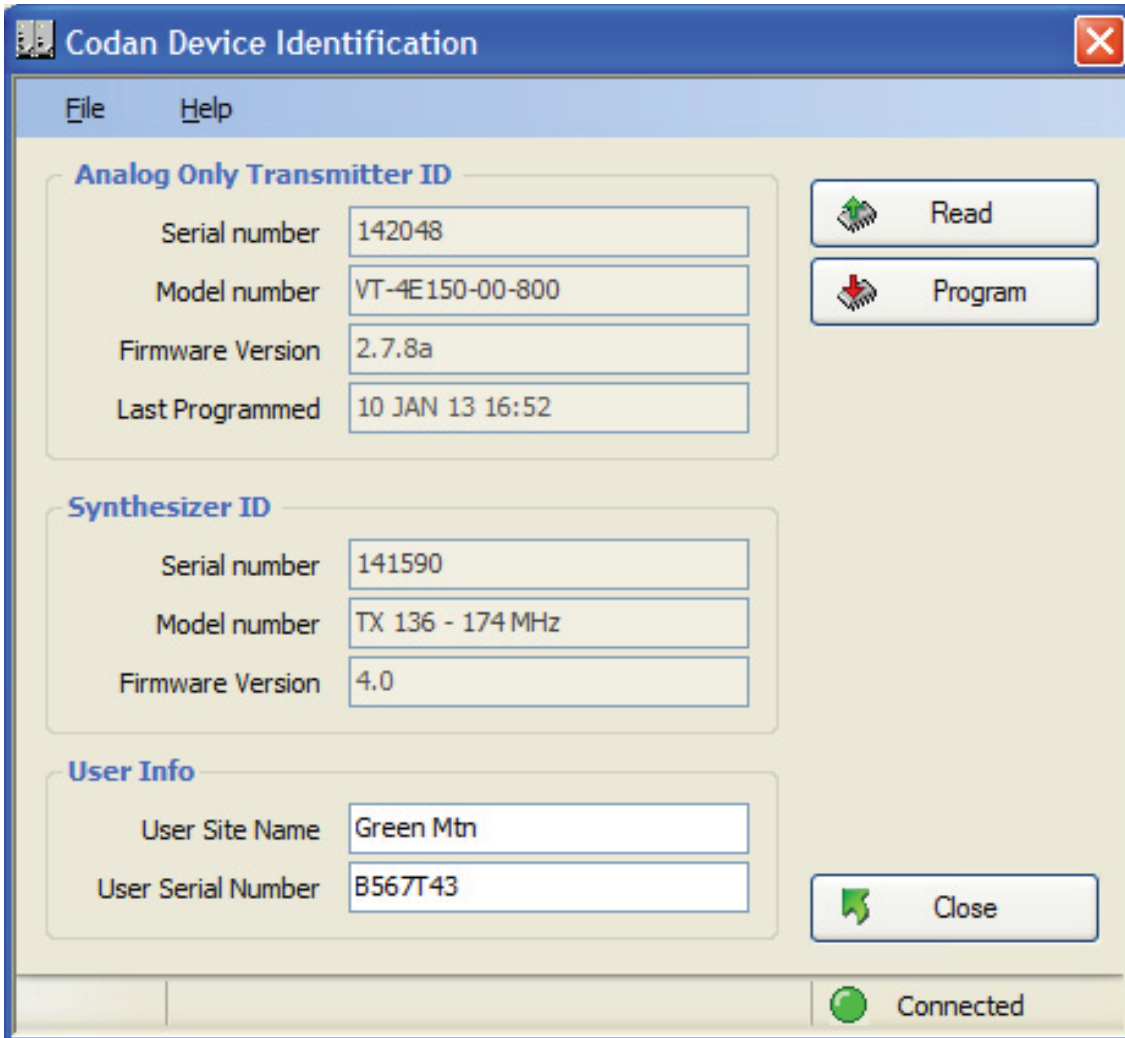
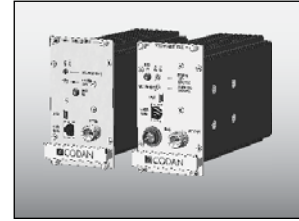

Figure 4-4: Transmitter ID Example



## CHAPTER 5: TECHNICAL INFORMATION

### AVAILABLE FREQUENCY BANDS

MT-4E paging systems are available in the VHF (136 - 174 MHz) and UHF (380 - 520 MHz, 768 - 869 MHz and 896 - 960 MHz) frequency bands.

The 470 - 520 MHz band is not available in Canada. The 380 - 406 MHz, 430 - 450 MHz, 470 - 520 MHz, 768 - 776 MHz, 798 - 824 MHz, 851 - 869 MHz, 896 - 902 MHz and 930 - 960 MHz Receivers are available in Class B only.

The 380 - 406 MHz and 470 - 520 MHz Transmitters have an RF power output of 0.5 to 6.0 Watts maximum. The 768 - 869 MHz and 896 - 960 MHz Transmitters have an RF power output of 0.5 to 3.0 Watts maximum.

Codan Radio Communications also has MT-3 VHF Lowband (29 - 50 MHz) transmitters and receivers that can be used in an analog (tone) paging systems.

### FRONT PANEL RJ45 CONNECTOR JACK

Codan MT-4E Radio Equipment has RJ45 jacks on the front panel of the Receiver and Transmitter. The jacks are used on P25 Digital communications and are not used for the MT-4E Paging System.

### CHANNEL SWITCHING RANGE

Although the receiver or transmitter channels can be programmed for any frequency in their band, the Maximum Switching Range of the module must not be exceeded or the module will require hardware re-tuning. The maximum switching range of the Receiver modules is +/- 2 MHz (136 - 520 MHz) or Unlimited (768 - 960 MHz), and the Transmitter modules are Unlimited, unless the VSWR Alarm is used (+/- 0.5 MHz for VSWR Alarm). For example, a VHF receiver may be programmed for any frequency between 136 to 174 MHz, but the front end helical filter has a typical pass band of 5 MHz, requiring re-tuning if two frequencies are used that are outside of that pass band.

## UPGRADING FIRMWARE VERSIONS

Codan Radio Communications allows customers to upgrade the firmware of their MT-4E Receivers and Transmitters via the Firmware Flashing Software and Firmware Upgrade files, available at the Codan website [www.danelec.com](http://www.danelec.com) under Products - Software Downloads.

A type A to 5 pin mini-type B USB cable is used to connect the USB port of an IBM compatible computer to the USB port on the front panel of the Receiver or Transmitter module.

It is not necessary to upgrade the firmware if the equipment is installed and is operating satisfactory. A firmware upgrade is typically only needed to fix minor software bugs or to upgrade the functionality of the equipment.

Firmware versions earlier than 1.6.0 must be returned to the factory for upgrading. Contact the Codan service department for more information.

## PAGING TRANSMITTER BLOCK DIAGRAM

Figure 5-1 shows a block diagram of an MT-4E digital or analog paging transmitter using a CI-PM-3 Paging Modulator Card.

The paging encoder can be connected to the CI-PM-3 through auxiliary connections on the subrack / motherboard or through a front panel DB-15 located on the front panel of the paging modulator card.

The analog / digital select control line of the paging encoder is fed to the transmitter and is used to control the signal path in the transmitter.

Analog audio is fed directly through the paging card to the balanced audio input of the transmitter.

The incoming paging data from the paging encoder is connected to the appropriate 2 or 4 level input. These signals are fed to control circuits that will turn on or off the appropriate pre-set control voltages, which are then routed to the modulation input of a high stability reference oscillator (OCXO). The modulated 10 MHz signal is fed to the reference input of the transmitter's synthesizer. A component of the digital page is also sent to the modulation input of the transmitter synthesizer through the direct modulation input of the transmitter.

If the system requires a great amount of frequency stability, as required in simulcast transmissions, an external high stability reference can be connected to the external reference input of the paging card. The reference signal in combination with the paging cards phase lock loop (PLL) circuit will condition the OCXO to +/-0.002ppm.



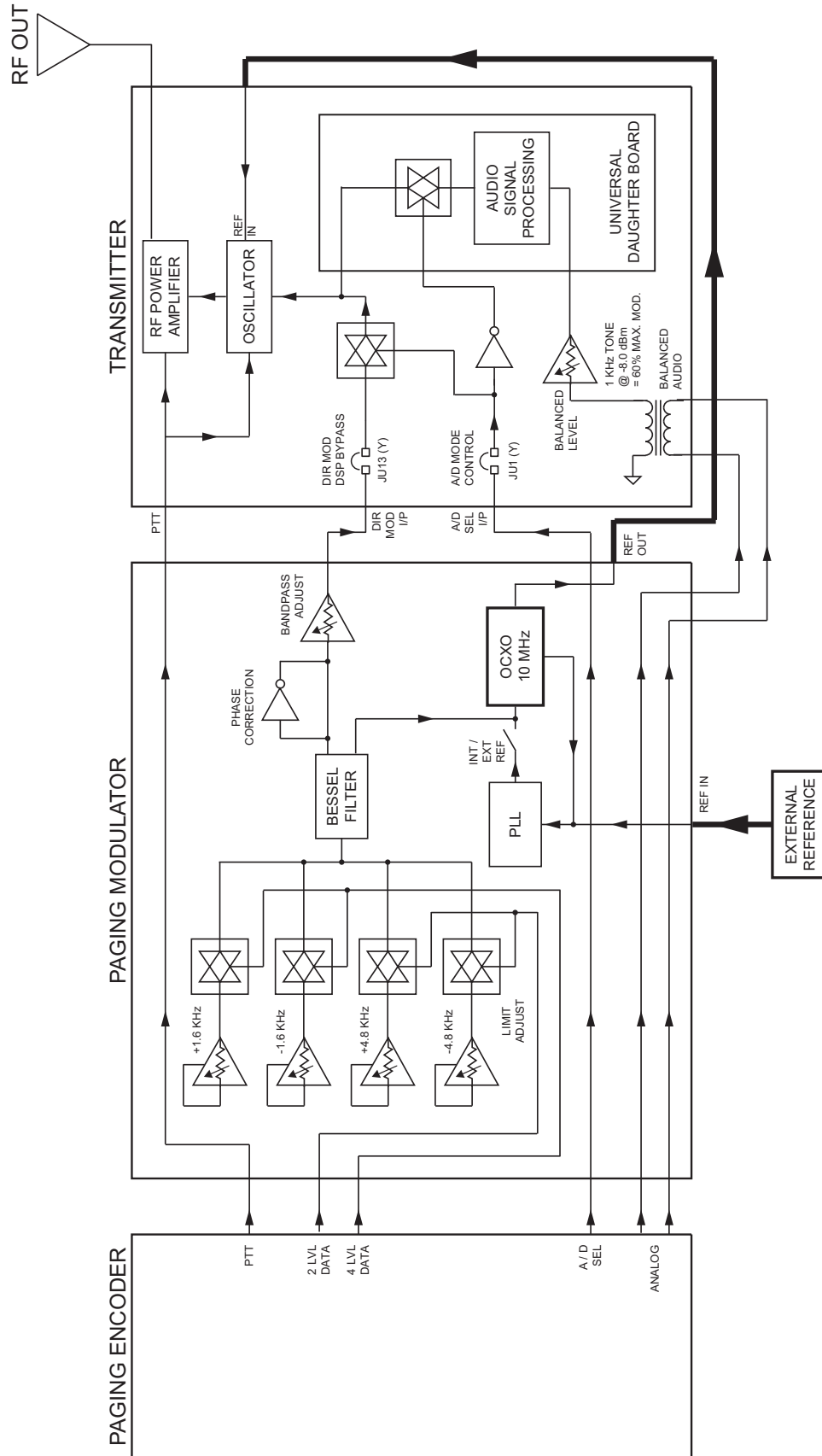

Figure 5-1: MT-4E Paging Transmitter Block Diagram

## NARROWBAND PAGING COVERAGE

Codan MT-4E paging systems support wideband (25 KHz) and narrowband (12.5 KHz) paging. The coverage area of the wideband / narrowband paging system is affected by two factors, the deviation of the transmitter and the IF bandwidth of the receiver.

When transitioning to a narrowband system from a wideband system, the transmitter deviation level is reduced and the receiver IF bandwidth will also be reduced. This may cause a minor reduction in coverage area. If the paging system is required to do both narrowband and wideband paging (or an older wideband receiver is still being used in a narrowband system), the wideband receiver will have reduced coverage when receiving narrowband pages.

The coverage area needed may be defined by different parameters called Channel Performance Criterion (CPC), and different values of those parameters. Depending on who is designing the system, the CPC may be SINAD or Bit Error Rate or another metric.

In analog systems there tends to be about a 2-3 dB difference in signal level required in narrowband vs. wideband when using 12 dB SINAD as the CPC. The coverage loss is determined by the distance required to make up that 2-3 dB signal level difference. However, if using 20 dB SINAD (dBS) or 25 dBS then the difference is as high as 6 dB.

These numbers depend on the receiver used in the field and have nothing to do with the transmitter, if the same type of transmitter is used in the entire system. If different transmitters are used in the system, the coverage could change based on the Signal-to-Noise (S/N) performance of each transmitter.

The TIA (Telecommunications Industry Association) standard TSB-88.1-C provides a recommended best practice reference for developers and suppliers of land mobile communications system design, modeling, simulation and spectrum management software, and automated tools. The following numbers are from TSB-88.1-C and show the Carrier to Noise level required to meet the specified CPC (either SINAD or BER). Unfortunately, no paging modulation types are listed.

Analog FM ± 5kHz (25 kHz) Wideband		Analog FM ± 2.5kHz (12.5 kHz) Narrowband		Wideband – Narrowband Difference
CPC (dB SINAD)	Carrier to Noise	CPC (dB SINAD)	Carrier to Noise	
12 dBS	4 dB	12 dBS	7 dB	3 dB
20 dBS	20 dB	20 dBS	26 dB	6 dB
25 dBS	27 dB	25 dBS	33 dB	6 dB

Difference of 3 dB for 12 dBS CPC and 6 dB for 20 & 25 dBS CPC.

EDACS® Digital (25 kHz) Wideband		EDACS® Digital (12.5 kHz) Narrowband		Wideband – Narrowband Difference
CPC (BER)	Carrier to Noise	CPC (BER)	Carrier to Noise	
5%	5.3 dB	5%	7.3 dB	2 dB
2%	15.7 dB	2%	17.7 dB	2 dB
1%	19.2 dB	1%	21.2 dB	2 dB

Difference of 2 dB for 5%, 2%, and 1 % BER.

# CONFIGURING CODAN MT-4E PAGING SYSTEMS

Codan MT-4E Paging Systems are typically pre-configured for the customers' application at the factory. It is important to contact the Codan Service section before changing jumpers or adjusting levels. The MT-4E transmitter and CI-PM-3 paging modulator are configured as a matched pair and should only be tuned together.

## Setting the internal reference carrier frequency

When the CI-PM-3 paging modulators on-board OCXO is used as a stand-alone frequency reference, the centre frequency of 10 MHz is factory-adjusted. Although altering this adjustment is not recommended, if it is necessary, ensure that the instructions provided in the CI-PM-3 Instruction Manual are carefully followed.

The transmitter requires that a kit is installed (A-PK-PM3) that adds a reference connector from the front panel REF OUT SMA connector on the CI-PM-3 paging modulator to the REF IN SMA connector on the transmitter.

## Setting the 2-level or 4-level deviation

The CI-PM-3 sets these deviation levels by allowing different operational amplifier circuits to be pre-set up to offset the carrier for the specific deviation levels. The incoming digital signal (paging data) from the paging encoder will turn the operational amplifier circuits on and off, allowing the carrier to be offset at the specific deviation levels.

Deviation levels for POCSAG are set at  $\pm 4.5$  KHz for wideband and  $\pm 2.25$  KHz for narrowband. FLEX™ 2-level deviation is set at  $\pm 4.8$  KHz for wideband and  $\pm 2.4$  KHz for narrowband. FLEX™ 4-level deviation adds  $\pm 1.6$  KHz for wideband and  $\pm 0.8$  KHz for narrowband. Multitone Mark IV / V / VI and VII uses a deviation level of  $\pm 4.5$  KHz. Golay Sequential Code uses a deviation level of  $\pm 5.0$  KHz.

## Configuring the external frequency reference

When a higher stability paging signal is required (for Simulcast operation), an external GPS or WWV referenced signal is connected to the front panel REF IN SMA connector on the CI-PM-3 paging modulator. This will discipline the on-board phase-locked loop OCXO oscillator.

This Page Intentionally Left Blank



---

Codan Radio Communications

43 Erie Street, Victoria, BC  
Canada, V8V 1P8  
[www.codanradio.com](http://www.codanradio.com)  
[LMRsales@codanradio.com](mailto:LMRsales@codanradio.com)

Toll Free Canada and USA  
Phone: 1-800-664-4066  
Fax: 1-877-750-0004

International  
Phone: 250-382-8268  
Fax: 250-382-6139

---

©2013 Codan Limited All Rights Reserved.

UG-004-2-0-0

 **CODAN**  
**RADIO COMMUNICATIONS**

[www.codanradio.com](http://www.codanradio.com)